



Nebraska Plumbing Heating & Cooling

#1

CALL US TODAY
(845) 783-6661

Your Proposal

Boiler Only

Customer: Town of Warwick

Address: 132 Kings Highway Warwick, NY 10990

Phone: (845) 986-3358

Email: clerk@townofwarwick.org

Consultation Code: ENGI4KD5X

Date Presented: Feb 3, 2026

Expiration Date: Apr 4, 2026

Presented by: David Smith

Phone: (845) 674-0361

Email: dsnebraskyplumbing@gmail.com

We handle all phases of plumbing, heating, cooling, and more, and we serve Orange County, N.Y., Dutchess County, N.Y., Rockland County, N.Y., and the entire Hudson Valley region. The **Nebraska Price Promise** guarantees that the estimate you receive upfront is the price you pay when the job is done! When you call Nebraska Plumbing, Heating & Cooling, you can be confident that the job will be done right, well, and with the utmost courtesy and professionalism.

Lic #1012. Put Lic #683

PROPOSAL NOTE

Boiler ONLY \$16,869.00 /

BOILER IS A CROWN BWF175CNT3SO

Boiler Only

Crown Boiler BWF Boiler 135,000 BTU

EQUIPMENT

Quantity: 1



Category: Boiler
Crown Boiler, Direct Vent Boilers, 135,000 BTU, Boiler
BWF157BL

Crown Direct Vent Gas Boiler. Gas-fired whole-house hot water boilers use natural gas or propane to provide hot water for heating. All units are gravity vented and require connection to an exhaust pipe or chimney to release fumes. These boilers provide the primary...

ACCESSORIES

Quantity: 1



Category: Services
Check Out Our Customer Reviews
CUSTOM-R5KP87 / Quantity: 1
Check out our Customer Reviews.

WHAT YOU'LL GET

Quantity: 7

Boiler Installation Kit: Includes Up to three (3) Zone Valves, New Expansion Tank, Back Flow Preventer, PRV, Air Scoop, Water Feeder, Shut off Valves and All Necessary Piping and Components

Install all materials necessary for proper operation and maximum efficiency Complete system start up

Install HVAC system listed above

MAINTAIN CLEAN WORK AREA: We will remove and dispose all excess materials and job debris. Old units will be recycled when possible.

Manufacture Warranty on Parts & One Year Labor Warranty

Remove existing equipment from the premises

z1 Includes all permits and inspection fees. Nebrasky will coordinate electrical and final inspections as need. Please Note: If the permit remains open due to a lack of response from the homeowner to schedule the necessary appointments, the homeowner will be responsible for any renewal applications or associated fees.

INVESTMENT DETAILS

Sale Price

\$16,869.00

Total Investment

The Total Investment is the total cost of the goods and services described in this proposal

\$16,869.00

PAYMENT TERMS

Payment Terms

For Credit card or Check Payments: 40% Deposit Due at Time of Signing. Balance Due Upon Completion.

For Financing: Loan application must be completed and documents must be signed by responsible party.

REVIEW AND SIGN PROPOSAL

Date:

TERMS AND CONDITIONS

To proceed with the above Quoted System Installation, I attest that I, the undersigned, am the owner/authorized representative/tenant of the premises at which the work mentioned above is to be done. I authorize you to perform the Quoted System Installation, and to use such labor and materials as you deem advisable. I authorize Nebraska Service Corp to proceed with the above work at the quoted rate, plus any applicable sales tax. (Customer to complete Capital Improvement Form to waive sales tax on all applicable system installs).

This proposal shall remain valid for ninety (90) days from the date of acceptance. If installation is scheduled beyond this period, pricing and terms are subject to review and adjustment at the sole discretion of Nebraska Plumbing, Heating & Cooling.

NEBRASKY LIMITED WARRANTY:

The obligation of Nebraska Service Corp shall be limited to replacement or repair of any material or equipment that shall prove defective during the stipulated warranty period. However it shall not include either consequential or special damages or loss, damage or expense directly arising from the use of such equipment or in combination with any other equipment or from any other cause. Equipment, special or otherwise, that is furnished to this contractor by the owner or his representatives for installation by this contractor shall bear the warranty only as designated by the manufacturer to the user. This contractor shall bear no responsibility for operation or continued operation following installation of customer supplied equipment and makes no representations or guarantees, express or implied, in respect to subject equipment.

This contractor shall not be liable for any damage due to failure to complete any specified work because of delays caused by strikes, fire, accidents or other conditions beyond our control. Nebraska is not responsible for the repair and/or remediation of any known or unknown pre-existing conditions, including, but not limited to, existing leaks, existing water damage and/or mold. All items stated are as per the New York State Article 36B, commonly referred to as the "Housing Merchant Implied Warranty"

Quotation rendered does not include any electrical wiring, excavation, temporary heat, painting or masonry work, unless otherwise stated. There are no promised agreements or understandings between parties to this contract except those contained in writing in this agreement or any additional work order.

A monthly service charge of 1.5% will be added after 30 days up \$1,000.00 on any amounts not paid in full at the time of service. In the event legal collection action is necessary, I agree to pay all reasonable attorney fees and court costs. In addition, if my check bounces, I understand that I could be liable for three times the amount of the check or \$100, whichever is more, plus the face value of the check and court costs. I have read and agreed to all the terms and conditions.

DISCLOSURES AND NOTICES

Model Numbers are subject to change based on availability. The Homeowner will be notified of any changes and these will be reviewed at time of service or pre-install walk through.

Sheet Rock Repairs:

Nebraska does not perform sheet rock work. This includes any repairs to preexisting damage and/or penetrations required for the installation of an HVAC or Plumbing system.

Nebraska is not liable for HVAC distribution systems installed by others. When replacing equipment and reusing existing distribution, Nebraska will not be liable for any issues associated with said distribution including but not limited to air flow, temperatures, noise, leaks, etc. Nebraska makes no guarantee written or otherwise regarding improvement or correction of any existing distribution issues.

Nebraska is not liable for any issues or NYS Electrical Code Compliance not directly connected to the HVAC system installed. Nebraska recommends contacting a licensed Electrician to access any issues outside of these systems.

If your proposals included all permits and inspection fees. Nebraska will assist in coordinating electrical and final inspections as needed to close the permit. Please Note: If the permit remains open due to a lack of response from the homeowner to schedule the necessary appointments, the homeowner will be responsible for any renewal applications or associated fees.

Refrigerant Safety Notice (R454B)

This estimate may include the installation of HVAC equipment using R 454B, an ASHRAE A2L-classified refrigerant—mildly flammable. While it can ignite, R 454B only supports slow burning under very specific conditions—its flame front moves at about ½ mile per hour, making ignition and flame spread highly unlikely under normal use. To ensure safety, all systems are built with certified built-in leak detection sensors that comply with EPA, UL, and ASHRAE standards. If a leak is detected, the system will automatically shut off to prevent any risk, as required by EPA Section 608 regulations. For more information on R 454B and its EPA listing under the SNAP program, visit the EPA site: www.epa.gov/snap/regulations-proposed-rules-and-final-rul

Air Conditioning Systems

AC Systems and Extreme Weather: During rare periods of extreme or prolonged Heat (above 85°F), your AC will continue to operate as designed, though indoor temperatures may be warmer than usual. Per NYS Energy Code, AC Systems and Heat Pumps are required to operate at maximum energy efficiency at the average regional temperatures. In these rare conditions, your system will be running as

efficiently as possible but may only be able to maintain warmer than preferred indoor temperatures. This is normal and expected. During these rare heat waves, your home may require closed blinds, fans or other steps for targeted comfort levels.

Heat Pumps

Heat Pumps and your Electric Bill:With a heat pump installation, you may notice an increase in your electric bill. However, this is typically offset by a significant reduction or elimination of fuel costs (oil, propane, or gas), leading to overall energy savings. Heat pumps are designed for efficiency, providing consistent comfort while reducing reliance on fossil fuels.

Heat Pumps and Extreme Weather:During rare periods of extreme cold (below 10°F), your heat pump will continue to operate as designed, though indoor temperatures may be cooler than usual. Per NYS Energy Code, Cold Climate Heat Pumps are required to operate at maximum energy efficiency at temps as low as 7°F. In these conditions, your heat pump will be running as efficiently as possible but may only be able to maintain cooler indoor temperatures. This is normal and expected. During these rare cold snaps, your home's backup heat source may be required for added comfort.

Rebate Programs

NYS Clean Heat:

If a rebate has been included on your proposal, Nebraska will be applying for a rebate on your behalf and there may be items required from the homeowner and/or the utility account holder. If the rebate is unable to be applied for or paid by NYS due to lack of information, photos or signatures required within the appropriate time frame, then the balance of the rebate will be billable. Please note that The NYS Clean Heat Program has reserved the right to change program incentives without notice.

Federal Tax Rebates:

Nebraska cannot apply for a federal tax credit on a homeowners behalf. An AHRI form and paid invoice can be provided upon request for the homeowner to apply with.

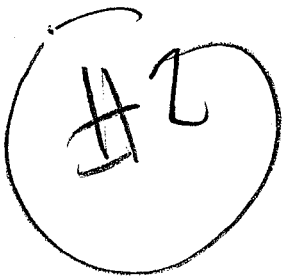

Expert Mechanical LLC
Plumbing and Heating
207 Reservoir Rd
Goshen NY 10924
845-258-1990
845-325-1529

2/11/26

Warwick Town Hall
132 Kings Hwy
Warwick NY 10990

Boiler replacement

We are pleased to submit this proposal for the following.

- 1- Cut out, remove, and discard the old gas boiler.
- 2- Supply and install a new Weit-McLain GV90+ Nat gas boiler. *(same Btu as original)*
- 3- Supply and install all the near-boiler piping.
- 4- Reconnect the gas line.
- 5- Reconnect the stainless-steel vent to the new boiler.
- 6- Reconnect all existing controls.
- 7- Fill and bleed the system.
- 8- Reconnect all wiring and complete start-up.

All work performed by Expert Mechanical LLC meets or exceeds all NYS building codes and includes a two-year warranty from the completion date.

Total proposal \$12,669.83

Thank you

DIMENSIONS

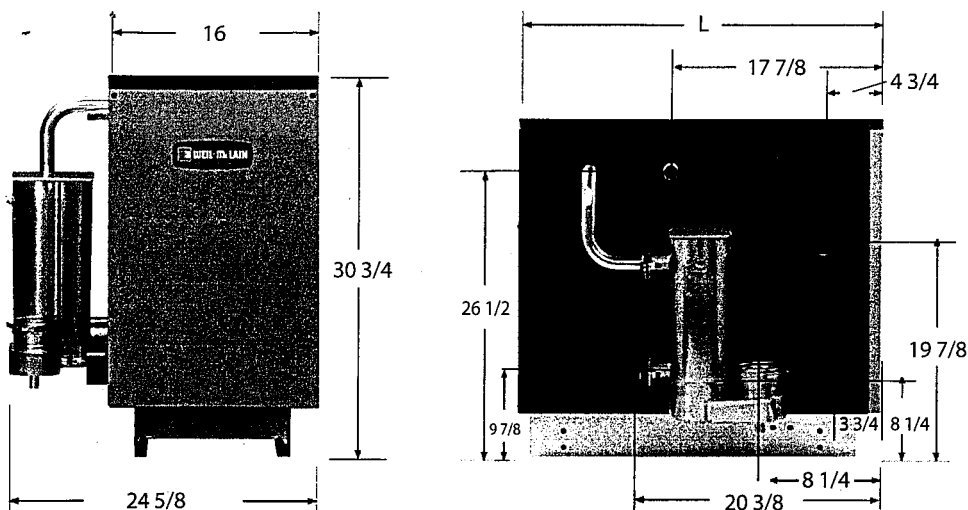

INSTALLATION FLEXIBILITY WITH MULTIPLE VENTING OPTIONS

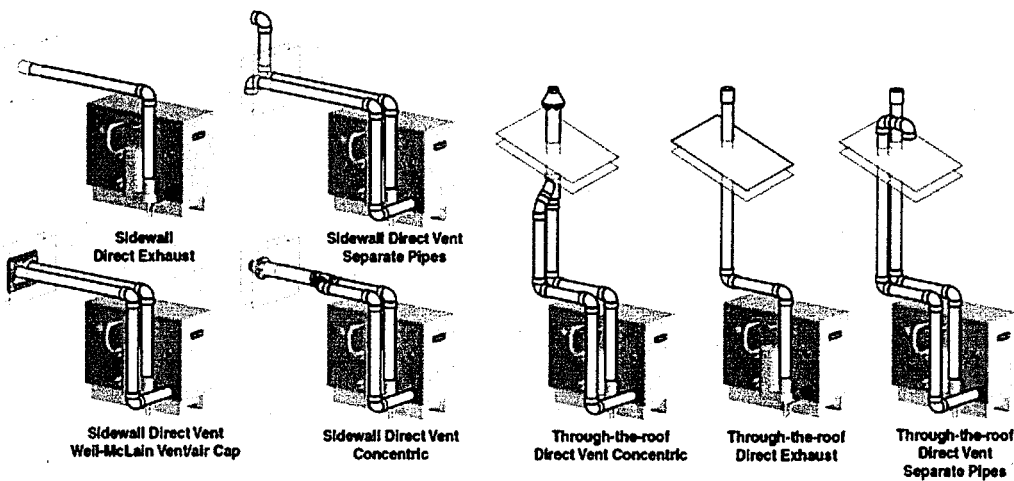

RATINGS

Model	Input MBH	DOE Heating Capacity MBH ¹	Net Water Rating MBH ²	AFUE	Vent Material	Vent Diameter ³	Venting Length of 3" Pipe	Boiler Water Content (Gal.)	Length (L)	Supply Tapping	Return Tapping	Gas Connection Size	Minimum Recommended Pipe Size	Approx. Shipping Weight (Lbs.)
GV90+3	70	65	56	91.9%	PVC, PP, CPVC, SS	3"	100'	3.8	30 3/4"	1"	1"	1/2"	1"	313
GV90+4	105	97	84	91.2%	PVC, PP, CPVC, SS	3"	100'	4.7	30 3/4"	1"	1"	1/2"	1"	353
GV90+5	140	130	113	91.4%	PVC, PP, CPVC, SS	3"	100'	6.0	37 3/4"	1"	1"	1/2"	1 1/4"	423
GV90+6	175	161	140	91.0%	PVC, PP, CPVC, SS	3"	100'	6.9	37 3/4"	1"	1"	1/2"	1 1/4"	464

Notes:

¹Based on standard test procedures prescribed by the United States Department of Energy.

²Net AHRI ratings are based on net installed radiation of sufficient quantity for the requirements of the building and nothing needs to be added for normal piping and pick-up. Ratings are based on a piping and pick-up allowance of 1.15. An additional allowance should be made for unusual piping and pick-up loads.

³GV90+ boilers must be vented directly to the outside.

STANDARD EQUIPMENT:

BOILER

- Control Module with Indicator Lights
- Integrated low-water cutoff, with test button
- Insulated Extended Steel Jacket
- Cast Iron Sections with Built-in Air Separator
- Stainless Steel Secondary Heat Exchanger with Air Separator
- Steel Base
- Blower Assembly with Observation Port
- Gas/Air Manifold Assembly
- Gas/Air Orifice Plate for Natural Gas (separate plate furnished for conversion to propane)
- Stainless Steel Burner Cone and Ring Assembly
- Negative Regulation Gas Valve
- Hot Surface Ignition System
- Air Pressure Switch
- System Circulator*
- Built-in-Bypass Circulator System with Sensor for Temperature Control*
- Condensate Drain Trap
- Sidewall Vent Termination Kit**
- 40VA Transformer
- Electrical Junction Box
- 30 PSI ASME Relief Valve (boiler sections & secondary heat exchanger tested for 50 PSI working pressure)
- Water Temperature Limit Switch
- Section Block Temperature Limit Switch
- Combination Pressure-Temperature Gauge
- Drain Valve

ADDITIONAL EQUIPMENT:

- Concentric Vent Kit
- Condensate Neutralizer Kit
- High Altitude Kit
- Outdoor Temperature Sensor
- Zone Interface Harness
- Water Treatment - Inhibitor & Test Kit

LIMITED TRANSFERABLE

WARRANTY:

- Residential: 20 Years Primary Heat Exchanger; 5 Years Secondary Heat Exchanger; 2 Years Parts
- Commercial: 10 Years Primary Heat Exchanger; 5 Years Secondary Heat Exchanger; 1 Years Parts

*Circulators supplied with boiler cannot be removed and cannot be used as a zone circulator in multiple zone systems.

** Only includes inside and outside metal termination plates and hardware (does not include plastic cap).

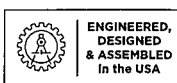

In the interest of continual improvement in product and performance, Weil-McLain reserves the right to change specifications without notice.

Fact: The majority of boiler installations today are for replacements of existing boilers on a prior designed high temperature water system, sending hot water out to a building's existing heat emitters, such as baseboards, radiators or fan coils.

Fact: Boiler efficiency is directly related to the operating water temperature of the home's heating system. As operating water temperature goes up, boiler efficiency goes down.

Typical cast iron boilers are designed to run on high temperature systems, and deliver standard efficiencies. But the GV90+ boiler is different, and specifically engineered to excel on high temperature systems, making it the best boiler choice to upgrade the efficiency of a baseboard, radiator or fan coil system.



The GV90+ is designed for homeowners who seek the perfect combination of ideal heating comfort, lower utility bills, peace-of-mind reliability and product longevity.

FEATURES THAT MAKE IT LAST

MAXIMUM HEAT EXCHANGER PERFORMANCE AND LONGEVITY

- Durable cast iron primary heat exchanger extends product life - it is not uncommon for cast iron boilers to last in excess of 40 years.
- Corrosion resistant stainless steel condensing secondary heat exchanger, increases efficiency up to 5% by recouping heat energy from exhaust normally wasted when vented from the building. The extra heat energy is then added and circulated through the baseboards or radiators to efficiently heat the home.

RELIABLE BOILER DESIGN

- Unlike most high efficiency boilers in the industry, the Weil-McLain GV90+ has extra-wide waterways (over 2") allowing sludge and debris, often present in older systems, to flow through easily. This limits scale build up, which reduces boiler efficiency, performance and can lead to premature boiler failure.
- Down-fired, counter flow boiler design improves boiler efficiency. The GV90+ offers (5) pass design in the primary heat exchanger and (2) pass design in the secondary heat exchanger maximizing heat transfer and optimizing boiler efficiency.

PROVEN CONTROL STRATEGY

- The control platform features error-proof, labeled, snap in connections. Tested at over 100,000 cycles, and boasting a failure rate of less than 1% over 20 years, it is sure to provide years of worry-free operation.
- Unlike traditional cast iron boilers, the GV90+ offers a unique control design allowing easy integration of outdoor reset to take advantage of low water temperatures and improve overall system energy cost savings.

SMART CIRCULATOR STRATEGY

- Built-in dual circulator strategy provides boiler protection - it can accept low return water temperatures (down to 60° F) with no additional mixing valves, pumps, wiring and installation labor - a savings of over \$500.
- The lower water temperature also allows homeowners the flexibility to add radiant heating for kitchens, baths or other living spaces without the added cost of special return temperature controls.

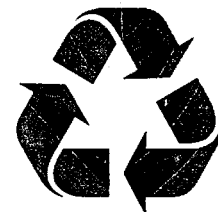
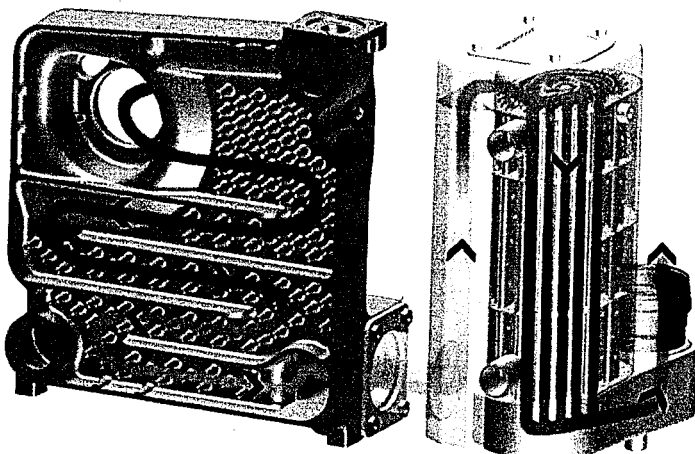

Cast iron boiler sections made with a portion of recycled metals

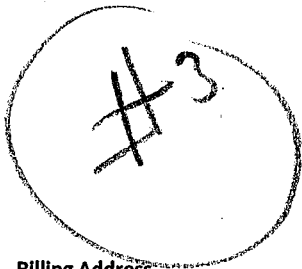

1136 Kings Highway, Suite 5
 Chester, NY 10918
 845-508-6271

Estimate 60185745
 Estimate Date 2/11/2026

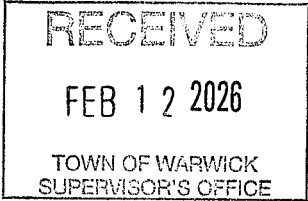

Billing Address
 Town Hall Senior Citizen Center
 136 Kings Highway
 Warwick, NY 10990 USA

Job Address
 Town Hall Senior Citizen Center
 136 Kings Highway
 Warwick, NY 10990 USA

Description of work

ALPINE AIR HEATING & COOLING

Family owned since 2006

We pride ourselves in our "Professionalism & Attention to Detail"

Installation of Weil McLain Boiler to include:

ITEMS TO BE REMOVED:

- *Removal and disposal of existing Hydronic Weil McLain Boiler
- *Removal and disposal of existing components including Ball Valves, Circulator, Water Feed Valve, Expansion Tank, and Flue Piping

ITEMS TO BE INSTALLED:

- *Installation of Cast Iron Weil McLain 115k BTU 84% AFUE Gas Fired Hydronic Boiler (performed Manual J Load Calculation and space only requires 82k BTU's)
- *Installation of all components needed to include:
 - *New Expansion Tank
 - *New Zone Valves
 - *New Backflow Water Preventer
 - *New Ball Valves
 - *New Copper Piping and Fittings
 - *New Black Gas piping
 - *New 3" Flue piping where necessary
 - *Start up and pressure test

*Taxes will be Waived due to Capital Improvement

WEIL MCLAIN WARRANTY:

- *2 Years on Parts
- *20 Years on Heat Exchanger

Payment Terms:

- Deposit of 30% down required to start project
- Balance due upon completion

Service #	Description	Quantity	Your Price	Total
Install-gasheat	Installation of Gas Heating System	1.00	\$12,459.00	\$12,459.00
			Sub-Total	\$12,459.00
			Tax	\$0.00
			Total Due	\$12,459.00
			Deposit/Downpayment	\$0.00

We greatly appreciate your business.

This estimate is a good faith estimate of work to be performed at 136 Kings Highway, Warwick, NY 10990 USA and is valid for 30 days. This estimate is based on our evaluation and does not include material price increases or additional labor and materials which may be required should unforeseen problems arise after the work has started. You understand that the final cost of the work may differ from the estimate, perhaps materially. You agree to pay regular rates for additional equipment or labor required for work beyond the proposed scope of work.

Alpine Air is not required to upgrade electrical panels or flue systems. This estimate does not include acquiring any permits or any

associated permit fees. The property owner is solely responsible for acquiring any necessary permits.

Alpine Air Heating & Air Conditioning retains full ownership to all equipment, whether or not installed, until paid in full. You authorize Alpine Air Heating & Air Conditioning to come onto the premises and remove equipment for which invoices remain 60 days past due. This estimate will serve as an invoice upon completion of the work. A minimum of 30% is due upon signing this estimate and the balance is due at the time work is completed. Cash discount may be available if listed on estimates. Cash discounts only available if entire invoice is paid by cash. After thirty days, a late fee of 10% of the unpaid balance and prior late fees will be added each month on a compounding basis. Unpaid invoices, as accruing, shall be a lien against the premises, which Alpine Air Heating & Air Conditioning may record at any time after 60 days. You agree to pay reasonable attorney fees and costs incurred for collections. Service and maintenance invoices are due at time of service.

Alpine Air Heating & Air Conditioning is fully insured and during installation shall take all reasonable precautions to avoid injury to persons and damage to property. Alpine Air Heating & Air Conditioning extends a one year labor warranty on installation related issues. This warranty begins when the system, or any components of the system are started up.

Alpine Air Heating & Air Conditioning's standard service coverage includes towns within Orange County, NY. For towns outside of this area, an additional charge will be added to invoices towards additional travel expenses.

#4

February 12, 2026

Mr. Robert Chocallo
Warwick Town Hall
132 Kings Highway
Warwick, NY 10990

RE: Replace existing Weil McLain boiler for the senior center.

Dear Mr. Chocallo:

We would like to thank you for the opportunity to quote the replacement of the existing boiler. Weil McLain still makes an improved version of what is there now which will simplify the replacement.

We propose to furnish the necessary labor, equipment, material, and supervision required for the above-referenced job site location.

Our proposal is based on the following:

1. Supply and install one (1) new Weil McLain GV-90 plus high efficiency boiler.
2. Supply and install necessary piping and fittings to connect to existing system.
3. Refill and purge system, operational check and commissioning.
4. All work is to be completed during normal working hours 7am to 3:30pm M-F.

Our proposal specifically excludes the following:

1. Premium time, phasing, or shift work hours.
2. Parts, repairs, labor or equipment not listed here.
3. All permits or permit fees.

The above can be completed for the sum of \$15,750.00 plus applicable taxes.

Proposal valid for thirty days.

If you have any questions or require additional information on the above, please do not hesitate to contact us.

Please sign where indicated, confirming your acceptance of the above-listed work. Kindly email the signed acceptance to our office, including your Purchase Order Number.

Authorized Signature: _____ Date: _____

Purchase Order: _____

Very truly yours,

AMI SERVICES, INC.

Frank Kuenneke, LEED AP

Account Executive

Email: fkuenneke@ami-servicesinc.com

Warwick Town Clerk

From: Tracy Gregoire <tracy@smallthingsinc.org>
Sent: Thursday, February 19, 2026 4:26 PM
To: Carmine Garritano
Cc: Barry Cheney; Michael Newhard; mjohndrow25@yahoo.com; Town of Warwick Supervisor; lsampson@orangecountygov.com; LLahiff@orangecountygov.com; ceoffice@orangecountygov.com; John Rader; tcosimano@optonline.net; VetJoe Inserra; stanmartin42@yahoo.com; rcarl80400@aol.com; vetRalphColon; ISNJS63@gmail.com; tpowerbren@aol.com; Warwick Town Clerk; Dhoovler@orangecountygov.com; Karl Brabenec; dpwsupervisor@villageofwarwick.org; jwadeson@nycourts.gov; Peter Barlet; Raina Abramson; Will Alexander for Sen. Skoufis; warwickems@gmail.com; warwickfire150@gmail.com; Judy Battista; HospiceJanice Valentino; K Kless; tbrown99@hotmail.com; LoFaro, Carl T.; Jacque & Dwayne HCC; Carmine Garritano; yesifarm@gmail.com; Dawn Mazur; dpwsupervisor@villageofwarwick.org; Eileen Patterson; Soney Frommeyer; HospiceM.Sutter; Karen Stemmler; Kathe McHugh; KFazio@ego.thechicagoschool.edu; lsampson@orangecountygov.co; Chji Support Services; NAMI Orange County, NY; Gonzalez, Brandon; tsputa; verboys@optonline.net
Subject: Re: Medical Mobile Vans

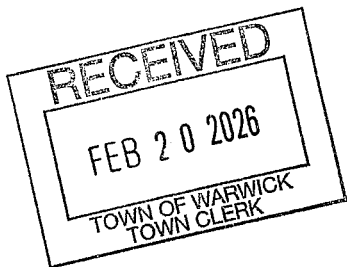

This is awesome news, Carmine! Thank you and Jose for facilitating this for our community, and for sharing the event.

Is there anything Small Things can do to support!

Best,
Tracy

On Tue, Feb 17, 2026 at 5:28 PM Carmine Garritano <warwickvfw4662@gmail.com> wrote:

To All :

This is an update on our efforts to provide a Medical Mobile unit for Veterans and the entire Warwick community in general.

Our Commander and I have had conversations with the County Health Dept. and our County Legislative representative Barry Cheney, who has been instrumental in making this happen. Our sincere thanks also to Ms. Lisa Lahiff, Deputy Commissioner, Orange County Health Dept., Ms. Laurisa Sampson, Public Health Corps Fellow, and Mr. Luis Abramson.

This is an update to the Medical Mobile Event which was originally scheduled for Mar 29th. The current date for the event will be May 31st with an updated time of 10am-1pm.

The Mobile units will be situated at the Pin Street Bowling Alley parking lot on Rt 94 and will be available to the entire community. Please mark your calendars for this event as it will be advantageous to all residents of Warwick and the Orange County Area. More information will follow with details on what the vans will be capable of providing, however preliminary plans are for testing of Blood Pressure, PSA, and Breast exams.

We are very excited to have secured this event for Veterans and the community at large.

Carmine Garritano, Sr. Vice Commander, Warwick Valley VFW Post 4662

Jose' Morales, Commander, Warwick Valley VFW Post 4662

On Wed, Oct 22, 2025 at 6:57 PM Carmine Garritano <warwickvfw4662@gmail.com> wrote:

To All Veterans (via Bcc) :

This is an update on our efforts to provide a Medical Mobile unit for Veterans and the Warwick community in general.

Our Commander and I have had conversations with the County Health Dept. and our County Legislative representative Barry Cheney, who has been instrumental in making this happen. Our sincere thanks also to Ms. Lisa Lahiff, Deputy Commissioner, Orange County Health Dept., Ms. Laurisa Sampson, Public Health Corps Fellow and Mr. Luis Abramson.

We have been successful in securing a SCHEDULED event to take place Mar. 29th of next year. The Mobile units will be situated at the Pin Street

Bowling Alley parking lot on Rt 94 and will be available from 12-3 pm to the entire community. Please mark your calendars for this event as it will be advantageous to all residents of Warwick and the Orange County Area. More information will follow with details on what the vans will be capable of providing, however preliminary plans are for testing of Blood Pressure, PSA, and Breast exams.

We are very excited to have secured this event for Veterans and the community at large.

Carmine Garritano, Sr. Vice Commander, Warwick Valley VFW Post 4662

Jose' Morales, Commander, Warwick Valley VFW Post 4662

	WORK DONE BY DPW		
WORK BEING DONE	LOCATION	REASON FOR WORK	LENGTH
CHIP SEAL			
PAVE ROAD			
MICRO SEAL			
TREE WORK	Merrits Island Rd.	Take down five dead trees	
BRUSH PICK UP			
	WORK DONE BY DPW		

<u>WORK BEING DONE</u>	<u>LOCATION</u>	<u>REASON FOR WORK</u>	<u>LENGTH</u>
MOWING			
BALL FIELDS			
POT HOLES	Town wide	Fill with cold mix	
ROAD REPAIR			
SNOW PLOWING	2/15,2/16,2/19,2/20,2/22, & 2/23/36	Plow and sand all roads	
	<u>WORK DONE BY DPW</u>		
<u>WORK BEING DONE</u>	<u>LOCATION</u>	<u>REASON FOR WORK</u>	<u>LENGTH</u>

SANDING			
VEHICLE MAINT.	As needed		
EMERG. REPAIRS	As needed		
ROAD SIGNS			
	<u>WORK DONE BY DPW</u>		
<u>WORK BEING DONE</u>	<u>LOCATION</u>	<u>REASON FOR WORK</u>	<u>LENGTH</u>
MAIL BOXES	Town wide	Replace as needed	

CURB REPAIR			
HAUL MATERIAL	GWL Stockpile	Haul sand/salt to GWL	
WATER DEPT.			
TOWN PARK			

X

Warwick Town Clerk

From: Marcy Gianattasio <mgianattasio@vernontwp.com>
Sent: Tuesday, February 10, 2026 11:38 AM
To: Hardyston Clerk; clerk@hamburgnj.org; Sussex Borough; mmorales@wantagetwp-nj.org; West Milford Clerk; Warwick Town Clerk; Scplanning@Sussex.nj.us
Subject: Ordinances Introduced
Attachments: 26-05 Affordable Housing Ordinance.pdf; 26-06 Development Fee Ordinance.pdf

Good morning,

The attached ordinances were introduced by the Vernon Township Council at their meeting of February 9, 2026 and will be on the March 9, 2026 agenda for public hearing.

Best regards,

Marcy Gianattasio

Marcy Gianattasio, RMC CMR
Vernon Township Municipal Clerk
21 Church Street
Vernon, NJ 07462
973-764-4055 Ext. 2238
973-764-6393 (fax)
mgianattasio@vernontwp.com

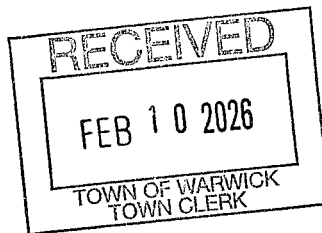

Township of West Milford
Passaic County, New Jersey

~ Ordinance 2026 – 007 ~

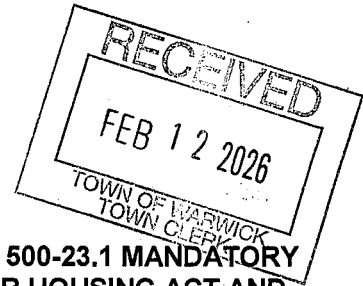

ORDINANCE AMENDING CHAPTER 500 ZONING TO ADD SECTION 500-23.1 MANDATORY SET-ASIDE ORDINANCE TO COMPLY WITH THE NEW JERSEY FAIR HOUSING ACT AND AFFORDABLE HOUSING OBLIGATIONS

WHEREAS, the Mayor and Township Council endorsed a Housing Element and Fair Share Plan dated June 5, 2025; and

WHEREAS, the Mayor and Township Council submitted the approved Housing Element and Fair Share Plan to the New Jersey Dispute Resolution Program for judicial review under the Fair Housing Act for Round 4 Affordable Housing Obligations; and

WHEREAS, no challenges to the Township's Housing Element and Fair Share Plan were filed with Dispute Resolution Program; and

WHEREAS, the Fair Housing Act requires all implementing ordinances and associated documents be adopted by March 15, 2026;

NOW THEREFORE, BE IT ORDAINED, by the Township Council of the Township of West Milford, in the County of Passaic, and State of New Jersey as follows:

SECTION 1. Chapter 500 "Zoning" Section 500-23.1 Mandatory Set-Aside Ordinance is added as follows:

§500-23.1 - MANDATORY SET-ASIDE ORDINANCE

- A. If the Township or Township Planning & Zoning Board permits the construction of multi-family or single-family attached residential development that is "approvable" and "developable," as defined at N.J.A.C. 5:93-1.3, the Township or the Township's Planning & Zoning Board shall require that a percentage of the residential units be set aside for low- and moderate-income households.
- B. This requirement shall apply beginning with the effective date of this Ordinance to any multi-family or single-family attached residential development, including the residential portion of a mixed-use project, which consists of five (5) or more new residential units at a density of six (6) units to the acre or more, whether permitted by a zoning amendment, a variance granted by the Township's Planning & Zoning Board, or adoption of a Redevelopment Plan or amended Redevelopment Plan in areas in need of redevelopment or rehabilitation.
- C. For any such development for which the Township's land use ordinances (e.g., zoning or an adopted Redevelopment Plan) already permitted residential development as of the effective date of this Ordinance, this requirement shall only apply if the Township permits an increase in approvable and developable gross residential density to at least twice the permitted approvable and developable gross residential density as of the effective date of this Ordinance.
- D. Nothing in this paragraph precludes the Township or the Township's Planning & Zoning Board from imposing an affordable housing set-aside in a development not required to have a set-aside pursuant to this paragraph consistent with N.J.S.A. 52:27D-311(h) and other applicable law.
- E. For all inclusionary projects, with the low- and moderate-income units, the minimum set-aside is twenty (20) percent, regardless of tenure.
- F. This requirement does not create any entitlement for a property owner or applicant for a zoning amendment, variance, or adoption of a Redevelopment Plan or amended Redevelopment Plan in areas in need of redevelopment or rehabilitation, or for approval of any particular proposed project.

G. Furthermore, this section shall not apply to developments containing four (4) or less dwelling units. All subdivision and site plan approvals of qualifying residential developments shall be conditioned upon compliance with the provisions of this section. Where a developer demolishes existing dwelling units and builds new dwelling units on the same site, the provisions of this section shall apply only if the net number of dwelling units is five (5) or more.

SECTION 2. All ordinances of the Township of West Milford, which are inconsistent with the provisions of this Ordinance, are hereby repealed to the extent of such inconsistency.

SECTION 3. If any section, subsection, sentence, clause or phrase of this Ordinance is for any reason held to be unconstitutional or invalid, such decision shall not affect the remaining portions of this Ordinance.

SECTION 4. This Ordinance shall take effect immediately upon final passage, approval, and publication as required by law.

SECTION 5. This Ordinance may be renumbered for codification purposes.

Introduced: February 11, 2026
Adopted:
Effective Date:

ATTEST:

TOWNSHIP OF WEST MILFORD
COUNTY OF PASSAIC
STATE OF NEW JERSEY

William Senande, Township Clerk

By: _____
Michele Dale, Mayor

Warwick Town Clerk

From: Deidre Ellis (ClerksOffice2@WestMilford.org) <ClerksOffice2@westmilford.org>
Sent: Thursday, February 12, 2026 9:13 AM
To: clerk@rockawaytownship.org; bsmith@bloomingdalenj.net; clerk@butlerborough.com; jbakalarczyk@hardyston.com; clerk@villageofgreenwoodlake.org; Michele Reilly; kiuele@kinnelonboro.org; clerk@ringwoodnj.net; townclerk@vernontwp.com; Warwick Town Clerk; dimhof@passaiccountynj.org; pcpb@passaiccountynj.org; salvatorep@passaiccountynj.org
Cc: Pamela Jordan (PlanningBoard@WestMilford.org)
Subject: Ordinance 2026-007 West Milford Township
Attachments: 2026-007-AmendChap500-AddSect23.1MandatorySet-Aside.pdf

Subject: Ordinance 2026-007 West Milford Township

February 12, 2026

TO: Borough of Bloomingdale
Borough of Butler
Borough of Kinnelon
Borough of Ringwood
Passaic County Clerk
Passaic County Planning Board
Township of Hardyston
Township of Jefferson
Township of Rockaway
Township of Vernon
Town of Warwick
Township of West Milford Planning Board
Village of Greenwood Lake

Re:
Ordinance 2026-007 - ORDINANCE AMENDING CHAPTER 500 ZONING TO ADD SECTION 500-23.1 MANDATORY SET-ASIDE ORDINANCE TO COMPLY WITH THE NEW JERSEY FAIR HOUSING ACT AND AFFORDABLE HOUSING OBLIGATIONS

Dear Sir/Madam:

Please take notice that the above Ordinance 2026-007 was introduced at a Regular Meeting of the Mayor and Governing Body of the Township of West Milford held on February 11, 2026.

Enclosed herewith is a copy of the Ordinance referenced above.

Deidre Ellis

Deidre Ellis
Clerk's Office
973-728-2714

Warning: This email transmission may contain confidential or privileged information. If you are not the intended recipient, you are hereby notified that any disclosure, copying, distribution, or taking of any action in reliance on the content of this message is strictly prohibited. If you have received this communication in error, please notify the sender by replying to this message, and then delete it from your system. Although the managing agency attempts to filter e-mails and attachments for viruses, it does not guarantee that either are virus free and accepts no liability for any damage sustained as a result of viruses. This message is automatically appended to each e-mail leaving the managing agency's e-mail system. ----Would you like to Unsubscribe from one of our mailing lists? Please visit our website www.WestMilford.org select the "Services" Tab & then "Email Subscriptions", select the mailing list which you subscribed and use the Unsubscribe box.----

TOWNSHIP OF VERNON

ORDINANCE #26-05

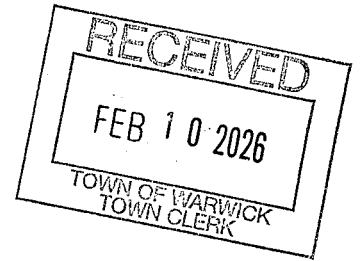

**ORDINANCE TO REPEAL AND REPLACE EXISTING CHAPTER 133,
"AFFORDABLE HOUSING" OF THE MUNICIPAL CODE OF THE TOWNSHIP OF
VERNON**

Ordinance repeals and replaces the existing Chapter 133, "Affordable Housing" of Vernon Township's municipal code.

Chapter 133 Affordable Housing

§ 133-1 Purpose; legislative authority.

- A. This article is intended to assure that low- and moderate-income units ("affordable units") are created with controls on affordability over time and that low- and moderate-income households shall occupy these units. This article shall apply except where inconsistent with applicable law.

§ 133-2 Definitions.

ACT

Means the Fair Housing Act, N.J.S.A. 52:27D-301 et seq.

ADMINISTRATIVE AGENT

Means the entity responsible for administering the affordability controls of this subchapter with respect to specific restricted units, as designated pursuant to N.J.S.A. 52:27D-321, N.J.A.C. 5:80-26.15, and 5:99-7.

AFFIRMATIVE MARKETING

Means a regional marketing strategy designed to attract buyers and/or renters of affordable units pursuant to N.J.A.C. 5:80-26.15.

AFFORDABILITY AVERAGE

Means the average percentage of regional median income at which restricted units in an affordable housing development are affordable to low- and moderate-income households.

AFFORDABLE

Means, in the case of an ownership unit, that the sales price for the unit conforms to the standards set forth at N.J.A.C. 5:80-26.7 and, in the case of a rental unit, that the rent for the unit conforms to the standards set forth at N.J.A.C. 5:80-26.13.

AFFORDABLE HOUSING DEVELOPMENT

Means a housing development all or a portion of which consists of restricted units.

AFFORDABLE HOUSING DEVELOPMENT

Means a development included in the Housing Element and Fair Share Plan, and includes, but is not limited to, an inclusionary development, a municipal construction project or a 100 percent affordable development

AFFORDABLE HOUSING PROGRAM(S)

Means any mechanism in a municipal Fair Share Plan prepared or implemented to address a municipality's fair share obligation.

AFFORDABLE HOUSING TRUST FUND or AHTF

Means that non-lapsing, revolving trust fund established in DCA pursuant to N.J.S.A. 52:27D-320 and N.J.A.C. 5:43 to be the repository of all State funds appropriated for affordable housing purposes. All references to the "Neighborhood Preservation Nonlapsing Revolving Fund" and "Balanced Housing" mean the AHTF.

AFFORDABLE UNIT

Means a housing unit proposed or created pursuant to the Act and approved for crediting by the Court and/or funded through an affordable housing trust fund.

AGE-RESTRICTED UNIT

Means a housing unit designed to meet the needs of, and intended exclusively for, the residents of an age-restricted segment of the population where the adult member of the family who is the head of the household for the purposes of determining income eligibility and rent is a minimum age of either 62 years, or 55 years and meets the provisions of 42 U.S.C. §§ 3601 through 3619, except that due to death, a surviving spouse of less than 55 years of age is permitted to continue to reside in the unit.

AGENCY

Means the New Jersey Housing and Mortgage Finance Agency established by P.L. 1983, c.530 (N.J.S.A. 55:14K-1 through 44) in, but not of, DCA.

ALTERNATIVE LIVING ARRANGEMENT

Means a structure in which households live in distinct bedrooms, yet share kitchen and plumbing facilities, central heat and common areas. Alternative living arrangements include, but are not limited to: transitional facilities for the homeless; Class A, B, C, D and E boarding homes as regulated by the State of New Jersey Department of Community Affairs; residential health care facilities as regulated by the New Jersey Department of Health; group homes for the developmentally disabled and mentally ill as licensed and/or regulated by the New Jersey Department of Human Services; and congregate living arrangements.

ASSISTED LIVING RESIDENCE

Means a facility that is licensed by the New Jersey Department of Health and Senior Services to provide apartment-style housing and congregate dining and to assure that assisted living services are available when needed for four or more adult persons unrelated to the proprietor and that offers units containing, at a minimum, one unfurnished room, a private bathroom, a kitchenette and a lockable door on the unit entrance.

CERTIFIED HOUSEHOLD

Means a household that has been certified by an administrative agent as a very-low-income household, a low-income household, or a moderate-income household

CHOICE

Means the no-longer-active Choices in Homeownership Incentives for Everyone Program, as it was authorized by the Agency.

COAH

Means the Council on Affordable Housing established in, but not of, DCA by the Act and that was abolished effective March 20, 2024 by section 3 of P.L. 2024, c.2 (N.J.S.A. 52:27D304.1).

COMPLIANCE CERTIFICATION

Means the certification issued to a municipality by the Dispute Resolution Program or by a county-level housing judge pursuant to section 3 at P.L. 2024, c.2, that protects the municipality from exclusionary zoning litigation during the current round of present and prospective need and through July 1 of the year the next affordable housing round begins, which is also known as a "judgment of compliance" resulting in an "order for repose." The term "compliance certification" includes a judgment of repose granted in an action filed pursuant to section 13 at P.L. 1985, c. 222 (N.J.S.A. 52:27D-313).

COUNTY-LEVEL HOUSING JUDGE

Means a judge appointed pursuant to section 5 of P.L. 2024, c.2 (N.J.S.A. 52:27D-313.2), to resolve disputes over the compliance of municipal fair share affordable housing obligations and municipal fair share plans and housing elements with the Act.

DCA or DEPARTMENT

Means the State of New Jersey Department of Community Affairs.

DEFICIENT HOUSING UNIT

Means a housing unit with health and safety code violations that requires the repair or replacement of a major system. A major system includes weatherization, roofing, plumbing (including wells), heating, electricity, sanitary plumbing (including septic systems), lead paint abatement and/or load bearing structural systems.

DEVELOPER

Means any person, partnership, association, company or corporation that is the legal or beneficial owner or owners of a lot or any land included in a proposed development including the holder of an option to contract to purchase, or other person having an enforceable proprietary interest in such land.

DEVELOPMENT

Means the division of a parcel of land into two or more parcels, the construction, reconstruction, conversion, structural alteration, relocation, or enlargement of any use or change in the use of any building or other structure, or of any mining, excavation or landfill, and any use or change in the use of any building or other structure, or land or extension of use of land, for which permission may be required pursuant to N.J.S.A. 40:55D-1, et seq.

DISPUTE RESOLUTION PROGRAM

Means the Affordable Housing Dispute Resolution Program, established pursuant to section 5 of P.L. 2024, c.2 (N.J.S.A. 52:27D-313.2).

DIVISION

Means the Division of Local Planning Services in DCA.

EXIT SALE

Means the first authorized non-exempt sale of a restricted unit following the end of the control period, which sale terminates the affordability controls on the unit.

FAIR SHARE PLAN

Means the plan or proposal, with accompanying ordinances and resolutions, by which a municipality proposes to satisfy its constitutional obligation to create a realistic opportunity to meet its fair share of low- and moderate-income housing needs of its region and which details the affirmative measures the municipality proposes to undertake to achieve its fair share of low- and moderate-income housing, as provided in the municipal housing element, and which addresses the development regulations necessary to implement the housing element, including, but not limited to, inclusionary requirements and development fees, and the elimination of unnecessary housing cost-generating features from the municipal land use ordinances and regulations.

HOUSEHOLD INCOME

Means a household's gross annual income calculated in a manner consistent with the determination of annual income pursuant to section 8 of the United States Housing Act of 1937 (Section 8), not in accordance with the determination of gross income for Federal income tax liability.

HOUSING REGION

Means a geographic area established pursuant to N.J.S.A. 52:27D-304.2b.

INCLUSIONARY DEVELOPMENT

Means a development containing both affordable units and market rate units. This term includes, but is not limited to: new construction, the conversion of a non-residential structure to residential use and the creation of new affordable units through the gut rehabilitation or reconstruction of a vacant residential structure.

LOW-INCOME HOUSEHOLD

Means a household with a total gross annual household income equal to 50% or less of the median household income.

LOW-INCOME UNIT

Means a restricted unit that is affordable to a low-income household.

MAJOR SYSTEM

Means the primary structural, mechanical, plumbing, electrical, fire protection, or occupant service components of a building which include but are not limited to, weatherization, roofing, plumbing (including wells), heating, electricity, sanitary plumbing (including septic systems), lead paint abatement and load bearing structural systems.

MARKET-RATE UNITS

Means housing not restricted to low- and moderate-income households that may sell or rent at any price.

MEDIAN INCOME

Means the median income by household size for the applicable housing region, as adopted annually by COAH or a successor entity approved by the Court.

MODERATE-INCOME HOUSEHOLD

Means a household with a total gross annual household income in excess of 50% but less than 80% of the median household income.

MODERATE-INCOME UNIT

Means a restricted unit that is affordable to a moderate-income household.

MULTIFAMILY DEVELOPMENT

Means a housing development with five or more dwelling units.

MUNICIPAL HOUSING LIAISON or MHL

Means an appointed municipal employee who is, pursuant to N.J.A.C. 5:99-6, responsible for oversight and/or administration of the affordable units created within the municipality.

NEW JERSEY HOUSING RESOURCE CENTER or HOUSING RESOURCE CENTER

Means the online affordable housing listing portal, or its successor, overseen by the Agency pursuant to N.J.S.A. 52:27D-321.3 et seq.

95/5 UNIT

Means a restricted ownership unit that is part of a housing element that received substantive certification from COAH pursuant to N.J.A.C. 5:93, as it was in effect at the time of the receipt of substantive certification, before October 1, 2001.

NON-EXEMPT SALE

Means any sale or transfer of ownership of a restricted unit to one's self or to another individual other than the transfer of ownership between spouses or civil union partners; the transfer of ownership between former spouses or civil union partners ordered as a result of a judicial decree of divorce or judicial separation, but not including sales to third parties; the transfer of ownership between family members as a result of inheritance; the transfer of ownership through an executor's deed to a class A beneficiary; and the transfer of ownership by court order.

NONPROFIT

Means an organization granted nonprofit status in accordance with section 501(c)(3) of the Internal Revenue Code.

PRICE DIFFERENTIAL

Means the difference between the controlled sale price of a restricted unit and the fair market value of the unit minus reasonable real estate broker fees, determined as of the date of a proposed contract of sale for the unit.

PRIOR ROUND UNIT

Means "Prior round unit" means a housing unit that addresses a municipality's fair share obligation from a round prior to the fourth round of affordable housing obligations, including any unit that: (1) received substantive certification from COAH; (2) is part of a third-round settlement agreement or judgment of compliance approved by a court of competent jurisdiction, inclusive of units created pursuant to a zoning designation adopted as part of the settlement agreement or judgment of compliance to create a realistic opportunity for development; (3) is subject to a grant agreement or other contract with either the State or a political subdivision thereof entered into prior to July 1, 2025, pursuant to either item (1) or (2) above; or (4) otherwise addresses a municipality's fair share obligation from a round prior to the fourth round of affordable housing obligations. A unit created after the

enactment of P.L. 2024, c. 2 (N.J.S.A. 52:27D-304.1) on March 20, 2024, is not a prior round unit unless: (1) it is created pursuant to a prior round development plan or zoning designation that received COAH or court approval on or before the cutoff date of June 30, 2025, or the date that the municipality adopts the implementing ordinances and resolutions for the fourth round of affordable housing obligations, whichever occurs sooner; and (2) its siting and creation are consistent with the form of the prior round development plan or zoning designation in effect as of the cutoff date, without any amendment or variance.

RANDOM SELECTION PROCESS

Means a lottery process by which currently income-eligible applicant-households are selected, at random, for placement in affordable housing units such that no preference is given to one applicant over another, except in the case of a veterans' preference where such an agreement exists; for purposes of matching household income and size with an appropriately priced and sized affordable unit; or another purpose allowed pursuant to N.J.A.C. 5:80-26.17(k)3.

REGIONAL ASSET LIMIT

Means the maximum housing value in each housing region affordable to a four-person household with an income at 80 percent of the regional median as defined by the Department's adopted Regional Income Limits published annually by the Department.

REHABILITATION

Means the repair, renovation, alteration or reconstruction of any building or structure, pursuant to the Rehabilitation Subcode, N.J.A.C. 5:23-6.

RENT

Means the gross monthly cost of a rental unit to the tenant, including the rent paid to the landlord, as well as an allowance for tenant-paid utilities computed in accordance with allowances published by DCA for its Section 8 program. With respect to units in assisted living residences, rent does not include charges for food and services.

RESTRICTED UNIT

Means a dwelling unit, whether a rental unit or ownership unit, that is subject to the affordability controls of this subchapter, but does not include a market-rate unit that was financed pursuant to UHORP, MONI, or CHOICE.

SINGLE-FAMILY DEVELOPMENT

Means a housing development with one to four dwelling units that does not meet the definition of "project" as defined in the Hotel and Multiple Dwelling Unit Law (N.J.S.A. 55:13A-1 through 13A-31).

UHAC

Means the Uniform Housing Affordability Controls set forth in N.J.A.C. 5:80-26, et seq.

VERY-LOW-INCOME HOUSEHOLD

Means a household with a household income less than or equal to 30 percent of the regional median income.

VERY-LOW-INCOME UNIT

Means a restricted unit that is affordable to a very low-income household.

VETERAN

Means a veteran as defined at N.J.S.A. 54:4-8.10.

VETERANS' PREFERENCE

Means the agreement between a municipality and a developer or residential development owner that allows for low- to moderate-income veterans to be given preference for up to 50 percent of units in relevant projects, as provided for at N.J.S.A. 52:27D-311j.

WEATHERIZATION

Means building insulation (for attic, exterior walls and crawl space), siding to improve energy efficiency, replacement storm windows, replacement storm doors, replacement windows and replacement doors, and is considered a major system for purposes of a rehabilitation program.

§ 133-3 Affordable housing programs.

Vernon Township has determined that it will use the following mechanisms to satisfy its affordable housing obligations.

A. A rehabilitation program.

- (1) Vernon Township's rehabilitation program shall be designed to renovate deficient housing units occupied by low- and moderate-income households such that, after rehabilitation, these units will comply with the New Jersey State Housing Code pursuant to N.J.A.C. 5:28.
- (2) Both owner occupied and renter occupied units shall be eligible for rehabilitation funds.
- (3) All rehabilitated units shall remain affordable to low- and moderate-income households for a period of 10 years (the control period). For owner occupied units the control period will be enforced with a lien and for renter occupied units the control period will be enforced with a deed restriction.
- (4) The Township shall dedicate a minimum of \$10,000 for each unit to be rehabilitated through this program, reflecting the minimum hard cost of rehabilitation for each unit.
- (5) The Township shall adopt a resolution committing to fund any shortfall in the rehabilitation programs for the Township.
- (6) The Township shall designate, subject to the approval of the Department, one or more Administrative Agents to administer the rehabilitation program in accordance with N.J.A.C. 5:96 and N.J.A.C. 5:97. The Administrative Agent(s) shall provide a rehabilitation manual for the owner occupancy rehabilitation program and a rehabilitation manual for the rental occupancy rehabilitation program to be adopted by resolution of the governing body and subject to approval of the Department. Both rehabilitation manuals shall be available for public inspection in the Office of the Municipal Clerk and in the office(s) of the Administrative Agent(s).
- (7) Units in a rehabilitation program shall be exempt from N.J.A.C. 5:97-9 and Uniform Housing Affordability Controls (UHAC), but shall be administered in accordance with the following:

- (a) If a unit is vacant, upon initial rental subsequent to rehabilitation, or if a renter-occupied unit is re-rented prior to the end of controls on affordability, the deed restriction shall require the unit to be rented to a low- or moderate-income household at an affordable rent and affirmatively marketed pursuant to N.J.A.C. 5:97-9 and UHAC.
- (b) If a unit is renter-occupied, upon completion of the rehabilitation, the maximum rate of rent shall be the lesser of the current rent or the maximum permitted rent pursuant to N.J.A.C. 5:97-9 and UHAC.
- (c) Rents in rehabilitated units may increase annually based on the standards in N.J.A.C. 5:97-9.
- (d) Applicant and/or tenant households shall be certified as income-eligible in accordance with N.J.A.C. 5:97-9 and UHAC, except that households in owner occupied units shall be exempt from the regional asset limit.

B. An alternative living arrangements program.

- (1) Alternative living arrangements include, but are not limited to: transitional facilities for the homeless; residential health care facilities as regulated by the New Jersey Department of Health and Senior Services; group homes for the developmentally disabled and mentally ill as licensed and/or regulated by the New Jersey Department of Human Services; and congregate living arrangements. Long term health care facilities including nursing homes, and Class A, B, C, D, and E boarding homes do not qualify as alternative living arrangements.

A. A Municipally Sponsored/100% Affordable Housing Program. The Township shall work with 100% Affordable Housing developers where sites become available to assist in providing 100% affordable opportunities including homes with Habitat for Humanity.

§ 133-4 New Construction.

A. Low/Moderate Split and Bedroom Distribution of Affordable Housing Units:

- 1. The fair share obligation shall be divided equally between low- and moderate-income units, except that where there is an odd number of affordable housing units, the extra unit shall be a low-income unit. At least 13% of all restricted rental units shall be very-low-income units (affordable to a household earning 30% or less of median income). The very-low-income units shall be counted as part of the required number of low-income units within the development. At least 25% of the obligation shall be met through rental units, including at least half in rental units available to families. A maximum of 30% may be age-restricted. At least half of the units in total shall be available to families.
- 2. In each affordable development, at least 50% of the restricted units within each bedroom distribution shall be low-income units.

3. Affordable developments that are not age-restricted shall be structured in conjunction with realistic market demands such that:
 - (a). The combined number of efficiency and one-bedroom units shall be no greater than 20% of the total low- and moderate-income units;
 - (b). At least 30% of all low- and moderate-income units shall be two-bedroom units;
 - (c). At least 20% of all low- and moderate-income units shall be three-bedroom units; and
 - (d). The remaining units may be allocated among two- and three-bedroom units at the discretion of the developer.
4. Affordable developments that are age-restricted shall be structured such that the number of bedrooms shall equal the number of age-restricted low- and moderate-income units within the inclusionary development. This standard may be met by having all one-bedroom units or by having a two-bedroom unit for each efficiency unit

B. Accessibility Requirements:

1. The first floor of all restricted townhouse dwelling units and all restricted units in all other multistory buildings shall be subject to the technical design standards of the Barrier Free SubCode, N.J.A.C. 5:23-7 and the following:
2. All restricted townhouse dwelling units and all restricted units in other multistory buildings in which a restricted dwelling unit is attached to at least one other dwelling unit shall have the following features
 - (a). An adaptable toilet and bathing facility on the first floor; and
 - (b). An adaptable kitchen on the first floor; and
 - (c). An interior accessible route of travel on the first floor; and
 - (d). An adaptable room that can be used as a bedroom, with a door or the casing for the installation of a door, on the first floor; and
 - (e). If not all of the foregoing requirements in 2(a) through 2(d) can be satisfied, then an interior accessible route of travel must be provided between stories within an individual unit, but if all of the terms of Subsections 2(a) through 2(d) above have been satisfied, then an interior accessible route of travel shall not be required between stories within an individual unit; and
 - (f). An accessible entranceway as set forth at P.L. 2005, c. 350 (N.J.S.A. 52:27D-311a, et seq.) and the Barrier Free SubCode, N.J.A.C. 5:23-7, or evidence that Vernon has collected funds from the developer sufficient to make 10% of the adaptable entrances in the development accessible:

- (1) Where a unit has been constructed with an adaptable entrance, upon the request of a person with disabilities who is purchasing or will reside in the dwelling unit, an accessible entrance shall be installed.
 - (2) To this end, the builder of restricted units shall deposit funds within the Township of Vernon's Affordable Housing Trust Fund sufficient to install accessible entrances in 10% of the affordable units that have been constructed with adaptable entrances.
 - (3) The funds deposited under Subsection (f)(2) above shall be used by the Township of Vernon for the sole purpose of making the adaptable entrance of an affordable unit accessible when requested to do so by a person with a disability who occupies or intends to occupy the unit and requires an accessible entrance.
 - (4) The developer of the restricted units shall submit a design plan and cost estimate to the Construction Official of the Township of Vernon for the conversion of adaptable to accessible entrances.
 - (5) Once the Construction Official has determined that the design plan to convert the unit entrances from adaptable to accessible meet the requirements of the Barrier Free SubCode, N.J.A.C. 5:23-7, and that the cost estimate of such conversion is reasonable, payment shall be made to the Township's Affordable Housing Trust Fund in care of the Township Chief Financial Officer who shall ensure that the funds are deposited into the Affordable Housing Trust Fund and appropriately earmarked.
- (g). Full compliance with the foregoing provisions shall not be required where an entity can demonstrate that it is "site impracticable" to meet the requirements. Determinations of site impracticability shall be in compliance with the Barrier Free SubCode, N.J.A.C. 5:23-7.

C. Design:

1. In inclusionary developments, to the extent possible, low- and moderate-income units shall be integrated with the market units.
2. In inclusionary developments, low- and moderate-income units shall have access to all of the same common elements and facilities as the market units.

D. Utilities:

1. Affordable units shall utilize the same type of heating source as market units within an inclusionary development.
2. Tenant-paid utilities included in the utility allowance shall be set forth in the lease and shall be consistent with the utility allowance approved by DCA for its Section 8 program.

E. Maximum Rents and Sales Prices:

1. In establishing rents and sales prices of affordable housing units, the Administrative Agent shall follow the procedures set forth in UHAC, utilizing the regional income limits established by COAH or a successor entity.
2. The maximum rent for restricted rental units within each affordable development shall be affordable to households earning no more than 60% of median income, and the average rent for restricted rental units shall be affordable to households earning no more than 52% of median income.
3. The developers and/or municipal sponsors of restricted rental units shall establish at least one rent for each bedroom type for both low-income and moderate-income units, provided that at least 13% of all low- and moderate-income rental units shall be affordable to very low-income households, earning 30% or less of the regional median household income.
4. The maximum sales price of restricted ownership units within each affordable development shall be affordable to households earning no more than 70% of median income, and each affordable development must achieve an affordability average of 55% for restricted ownership units; in achieving this affordability average, moderate-income ownership units must be available for at least three different sales prices for each bedroom type, and low-income ownership units must be available for at least two different sales prices for each bedroom type.
5. In determining the initial sales prices and rent levels for compliance with the affordability average requirements for restricted units other than assisted living facilities and age-restricted developments, the following standards shall be used:
 - (a). A studio shall be affordable to a one-person household;
 - (b). A one-bedroom unit shall be affordable to a 1 1/2 person household;
 - (c). A two-bedroom unit shall be affordable to a three-person household;
 - (d). A three-bedroom unit shall be affordable to a 4 1/2 person household; and
 - (e). A four-bedroom unit shall be affordable to a six-person household.
6. In determining the initial sales prices and rents for compliance with the affordability average requirements for restricted units in assisted living facilities and age-restricted developments, the following standards shall be used:
 - (a). A studio shall be affordable to a one-person household;
 - (b). A one-bedroom unit shall be affordable to a 1 1/2 person household; and
 - (c). A two-bedroom unit shall be affordable to a two-person household or to two one-person households.

7. The initial purchase price for all restricted ownership units shall be calculated so that the monthly carrying cost of the unit, including principal and interest (based on a mortgage loan equal to 95% of the purchase price and the Federal Reserve H. 15 rate of interest), taxes, homeowner and private mortgage insurance and condominium or homeowner association fees do not exceed 28% of the eligible monthly income of the appropriate size household as determined under N.J.A.C. 5:80-26.4, as may be amended and supplemented; provided, however, that the price shall be subject to the affordability average requirement of N.J.A.C. 5:80-26.3, as may be amended and supplemented.
8. The initial rent for a restricted rental unit shall be calculated so as not to exceed 30% of the eligible monthly income of the appropriate size household, including an allowance for tenant paid utilities, as determined under N.J.A.C. 5:80-26.4, as may be amended and supplemented; provided, however, that the rent shall be subject to the affordability average requirement of N.J.A.C. 5:80-26.3, as may be amended and supplemented.
9. The price of owner-occupied low- and moderate-income units may increase annually based on the percentage increase in the regional median income limit for each housing region. In no event shall the maximum resale price established by the Administrative Agent be lower than the last recorded purchase price.
10. The rent of low- and moderate-income units may be increased annually based on the permitted percentage increase in the Housing Consumer Price Index for New Jersey. This increase shall not exceed 9% in any one year. Rents for units constructed pursuant to low- income housing tax credit regulations shall be indexed pursuant to the regulations governing low- income housing tax credits.
11. All deed restricted affordable rental units will be subject to an annual rental recertification process to ensure that income eligible households continue to reside in the Township's portfolio of rental units.

F. Affordable Housing Set-Asides.

1. Any residential or mixed-use development, within the public sewer service area of the municipality, that produces five or more housing units, shall be required to provide for affordable housing set-asides of at least 20% of the total housing units regardless of tenancy. When any calculation of the percentage of affordable units required to be divided results in a fractional unit of 1/2 or more, the fraction shall be rounded up to the next whole unit. When a calculation results in a fraction of less than 1/2, the fraction shall be rounded down to the previous whole unit.

§ 133-5 Minimum Floor Area Requirements and Standards for Low- and Moderate-Income Housing Units.

Developments approved as part of a compliance certification or that otherwise contain restricted units subject to the UHAC regulations shall satisfy the following occupancy standards:

- A. For any 100-percent affordable development comprising one or more restricted units:

1. Restricted units must meet the minimum square footage required for the number of inhabitants for which the unit is marketed and the minimum square footage required for each bedroom, as set forth in the applicable municipal code or the Neighborhood Preservation Balanced Housing rules at N.J.A.C. 5:43-2.4, whichever is greater.
 2. Each bedroom in each restricted unit must have at least one window; and
 3. Restricted units must include adequate air conditioning and heating.
- B. For developments comprising market-rate rental units and restricted rental units:
1. Restricted units must use the same building materials and architectural design elements (for example, plumbing, insulation, or siding) as market-rate units of the same unit type (for example, flat or townhome) within the same development, except that restricted units and market-rate units may use different interior finishes;
 2. Restricted units and market-rate units within the same affordable development must be sited such that restricted units are not concentrated in less desirable locations;
 3. Restricted units may not be physically clustered so as to segregate restricted and market-rate units within the same development or within the same building, but must be interspersed throughout the development, except that age-restricted and supportive housing units may be physically clustered if the clustering facilitates the provision of on-site medical services or on-site social services;
 4. Residents of restricted units must be offered the same access to communal amenities as residents of market-rate units within the same affordable development. Examples of communal amenities include, but are not limited to, community pools, fitness and recreation centers, playgrounds, common rooms and outdoor spaces, and building entrances and exits;
 5. Restricted units must include adequate air conditioning and heating and, if market-rate units provide cooling and heating, restricted units must use the same type of cooling and heating sources as market-rate units of the same unit type;
 6. Each bedroom in each restricted unit must have at least one window;
 7. Restricted units must be of the same unit type as market-rate units within the same building; and
 8. Restricted units and bedrooms must be no less than 90 percent of the minimum size prescribed by the Neighborhood Preservation Balanced Housing rules at N.J.A.C. 5:43-2.4.
- C. For developments containing for-sale units, including those with a mix of rental and for-sale units, subsection b above shall govern the rental units, while for-sale units shall adhere to the following:

1. Restricted units must use the same building standards as market-rate units of the same unit type (for example, flat, townhome, or single-family home), except that restricted units and market-rate units may use different interior finishes;
2. Restricted units may be clustered, provided that the buildings or housing product types containing the restricted units are integrated throughout the development and are not concentrated in an undesirable location or in undesirable locations;
3. Restricted units may be of different housing product types than market-rate units, provided that developments containing market-rate duplexes, townhomes, and/or single-family homes offer restricted housing options that also include duplexes, townhomes, and/or single-family homes;
4. Restricted units must meet the minimum square footage required for the number of inhabitants for which the unit is marketed and the minimum square footage required for each bedroom, as set forth in the Neighborhood Preservation Balanced Housing rules at N.J.A.C. 5:43-2.4;
5. Penthouse and end units may be reserved for market-rate sale, provided that the overall number, value, and distribution of affordable units across the development is not negatively impacted by such reservation(s);
6. Residents of restricted units must be offered the same access to communal amenities as residents of market-rate units within the same affordable development. Examples of communal amenities include, but are not limited to, community pools, fitness and recreation centers, playgrounds, common rooms and outdoor spaces, and building entrances and exits;
7. Each bedroom in each restricted unit must have at least one window; and
8. Restricted units must include adequate air conditioning and heating.

§ 133-6 Occupancy Standards.

In referring certified households to specific restricted units, the administrative agent shall strive, to the extent feasible and without causing an undue delay in occupying the unit to:

- A. Ensure each bedroom is occupied by at least one person, except for age-restricted units;
- B. Provide a bedroom for every two adult occupants;
- C. Provide a bedroom for every occupant under the age of 18, unless the household requests a different arrangement, which arrangement may not result in more than two occupants under the age of 18 occupying any bedroom; and
- D. Avoid placing a one-person household into a unit with more than one bedroom.

§ 133-7 Control Periods for Restricted Ownership Units and Enforcement Mechanisms.

- A. Control periods for restricted ownership units shall be in accordance with N.J.A.C. 5:80-26.6, as may be amended and supplemented, and each restricted ownership unit must

remain subject to the requirements of this subchapter until the end of the control period specified in the deed restriction unless the municipality in which the unit is located elects to extend the unit's restriction in compliance with subsection 1 below. A restricted ownership unit must remain subject to the requirements of this subchapter for a period of at least 30 years; provided, however, that:

1. Any unit that, prior to the effective date of the amendments to this subchapter as promulgated pursuant to P.L. 2024, c.2 (N.J.S.A. 52:27D-304.1), received substantive certification from COAH, was part of a judgment of compliance from a court of competent jurisdiction, or became subject to a grant agreement or other contract with either the State or a political subdivision thereof, will have its control period governed by such grant of substantive certification, judgment, grant agreement, or contract; and
2. 95/5 units are subject to the option and price restriction rules set forth a N.J.A.C. 5:80-26.21 through 26.27; and
3. Units for which affordability controls have been extended are subject to a minimum period of extension of 30 years, except that the extension period may be limited to 20 years if the original and extended terms of affordability controls, in combination, are at least 60 years.
4. The affordability control period for a restricted ownership unit shall commence on the date the initial certified household takes title to the unit and terminates at the first non-exempt sale after the end of the deed-restricted affordability period, if and only if the municipality does not exercise the right of first refusal to extend the control period in accordance with N.J.A.C. 5:80-26.6(h), and if and only if the seller has provided the municipality with at least 60 days' notice of the seller's intention to make the first nonexempt sale.

§ 133-8 Price Restrictions for Restricted Ownership Units, Homeowner Association Fees and Resale Prices.

- A. Price restrictions for restricted ownership units shall be in accordance with N.J.A.C. 5:80-26.17, as may be amended and supplemented.

§ 133-9 Buyer Income Eligibility.

- A. When reviewing an applicant household's income to determine eligibility, the administrative agent shall compare the applicant household's annual income to the regional low- and moderate-income limits calculated pursuant to N.J.A.C. 5:80-26.3.
- B. For the purposes of this section, the administrative agent shall determine household income in accordance with the procedure for calculating annual income at the time of initial occupancy and assistance, stipulated at 24 CFR § 5.609, as it may be updated from time to time, and described in Chapter 5 of HUD Handbook 4350.3: Occupancy Requirements of Subsidized Multifamily Housing Programs, which is available at https://www.hud.gov/program_offices/administration/hudclips/handbooks/hsqh/4350.3.

§ 133-10 Limitations on Indebtedness Secured By Ownership Unit; Subordination.

- A. Prior to incurring any indebtedness to be secured by an ownership unit, the owner shall submit to the administrative agent a notice of intent to incur such indebtedness (for example, a home equity loan or solar loan), in such form and with such documentary support as determined by the administrative agent, and the owner may not incur any such indebtedness unless and until the administrative agent has determined and confirmed in writing that the proposed indebtedness complies with the provisions of this section.
- B. With the exception of original purchase money mortgages, during a control period, neither an owner nor a lender shall at any time cause or permit the total indebtedness secured by an ownership unit to exceed 95 percent of the maximum allowable resale price of that unit, as such price is determined by the administrative agent in accordance with N.J.A.C. 5:8026.7(c).

§ 133-11 Capital Improvements to Ownership Units.

- A. The owner of an ownership unit may apply to the administrative agent to increase the maximum sales price for the unit to reflect eligible capital improvements made since they purchased the unit. Eligible capital improvements are limited to those that make the unit suitable for a larger household or that add an additional bathroom. However, the maximum sale price of an improved housing unit may not exceed the limits of affordability for the larger household.
- B. Upon the resale of a restricted ownership unit, all items of property that are permanently affixed to the unit or were included when the unit was initially restricted (for example, refrigerator, range, washer, dryer, dishwasher, wall-to-wall carpeting) are included in the maximum allowable resale price. Other items may be sold to the purchaser at a reasonable price that has been approved by the administrative agent at the time of signing the agreement to purchase. The purchase of central air conditioning installed subsequent to the initial sale of the unit and not included in the base price may be made a condition of the unit resale provided the price, subject to 10-year, straight-line depreciation, has been approved by the administrative agent. Unless otherwise approved by the administrative agent, the purchase of any property other than central air conditioning may not be made a condition of the unit resale. The owner and the purchaser must personally certify at the time of closing that no unapproved transfer of funds for the purpose of selling and receiving property has taken place at resale.
- C. Capital expenditures approved in writing by the administrative agent for non-cosmetic replacement of existing items of property or non-cosmetic improvement to the property (for example, replacement of a leaky roof, installation of a solar energy system owned by the homeowner, installation of energy-efficient windows, or replacement of broken appliances with ENERGY STAR-labeled products) do not affect the maximum sale price, but will be factored into calculating reductions to the recapture amount pursuant to N.J.A.C. 5:80-26.6(c)1.

§ 133-12 Control Period for Restricted Rental Units.

- A. Each restricted rental unit must remain subject to the requirements of this subchapter until the end of the control period specified in the unit deed restriction, unless the unit's restriction is extinguished in compliance with (e) below or extended in compliance with (f) below. A restricted rental unit must remain subject to the requirements of this subchapter for a period of at least 40 years; provided, however, that the control period of any unit that,

prior to the effective date of the amendments to this subchapter as promulgated pursuant to P.L. 2024, c.2 (N.J.S.A. 52:27D-304.1), received substantive certification from COAH, was part of a judgment of compliance from a court of competent jurisdiction, or became subject to a grant agreement or other contract with either the State or a political subdivision thereof will be governed by such grant of substantive certification, judgment, grant agreement, or contract.

1. Rental units created on or after January 1, 2025, and which are subject to affordability controls for low- and/or moderate-income families pursuant to this subchapter are subject to a deed restriction of not less than 40 years.
 2. Any project composed entirely of rental units subject to the affordability controls of this section that does not participate in a State-administered preservation program may elect to extinguish the existing deed restriction beginning 30 years following the start of the deed restriction, regardless of original length, provided that the project enters into a new deed restriction of at least 30 years and that the project has applied for and obtained a refinancing and/or has commenced an approved rehabilitation for the purpose of preservation.
 3. Any project composed entirely of rental units subject to the affordability controls of this section that participates in a State-administered preservation program may elect to extinguish the existing deed restriction prior to the 30th year, regardless of original length, provided that the project enters into a new deed restriction that, in combination with the original deed restriction, totals at least 60 years.
- B. The affordability control period for the restricted rental units in a development commences on the first date that a unit is issued a certificate of occupancy and terminates only at the end of the control period specified in the deed restriction or at such time that the municipality releases the unit from the requirements in N.J.A.C. 5:80-26.12(e). For any restricted rental units occupied at the end of the control period specified in the deed restriction or the time at which the municipality releases the unit from the requirements, the affordability controls set forth in this subchapter remain in effect until the date on which the occupant household vacates the rental unit provided that the occupant household continues to earn a household income of less than 80 percent of the applicable regional median income. If, at that time, a rental household's income exceeds 80 percent of the regional median income, the rental rate restriction will expire at the later of either the next scheduled lease renewal or in 60 days.
- C. Deeds of all real property that include restricted rental units must contain deed restriction language that conforms with the requirements of N.J.A.C. 5:80-26.12.
- D. A restricted rental unit remains subject to the affordability controls above despite the occurrence of any of the following events:
1. Sublease or assignment of the lease of the unit;
 2. A sale or other voluntary transfer of [the] ownership of the unit;
 3. The entry and enforcement of any judgment of foreclosure or grant of a deed in lieu of foreclosure; or

4. The release from affordability restrictions at the end of the affordability control period, until occupancy by the first new tenant subsequent to the release of controls.

§ 133-13 Rent Restrictions For Rental Units; Leases.

- A. Rent restrictions shall comply with N.J.A.C. 5:80-26.13. The administrative agent shall set the initial rent for a restricted rental unit. If the unit is receiving assistance pursuant to the AHTF, the initial rent must be consistent with the AHTF grant agreement. The initial rent must be calculated so as not to exceed 30 percent of the eligible monthly income of the appropriate household size as determined pursuant to N.J.A.C. 5:80-26.5; provided, however, that the rent is subject to the affordability average requirement at N.J.A.C. 5:80-26.4.

§ 133-14 Tenant Income Eligibility.

- A. Tenant income eligibility shall be in accordance with N.J.A.C. 5:80-26.14, and is determined as follows:

1. Very-low-income rental units shall be reserved for households with a gross household income less than or equal to 30% of the regional median income.
2. Low-income rental units shall be reserved for households with a gross household income less than or equal to 50% of the regional median income.
3. Moderate-income rental units shall be reserved for households with a gross household income less than 80% of the regional median income.

- B. The Administrative Agent shall certify a household as eligible for a restricted rental unit when the household is a very low-income household, low-income household or a moderate-income household, as applicable to the unit, and the rent proposed for the unit does not exceed 35% (40% for age-restricted units) of the household's eligible monthly income as determined pursuant to N.J.A.C. 5:80-26.16, as may be amended and supplemented; provided, however, that this limit may be exceeded if one or more of the following circumstances exists:

1. The household currently pays more than 35% (40% for households eligible for age-restricted units) of its gross household income for rent, and the proposed rent will reduce its housing costs;
2. The household has consistently paid more than 35% (40% for households eligible for age-restricted units) of eligible monthly income for rent in the past and has proven its ability to pay;
3. The household is currently in substandard or overcrowded living conditions;
4. The household documents the existence of assets with which the household proposes to supplement the rent payments; or

5. The household documents proposed third-party assistance from an outside source, such as a family member, in a form acceptable to the administrative agent and the owner of the unit.
- C. The applicant shall file documentation sufficient to establish the existence of the circumstances in a1 through b5 above with the Administrative Agent, who shall counsel the household on budgeting.

§ 133-15 Municipal Housing Liaison.

- A. The Township of Vernon shall appoint a specific municipal employee to serve as a Municipal Housing Liaison responsible for administering the affordable housing program, including affordability controls, the Affirmative "Marketing Plan, monitoring and reporting, and, where applicable, supervising any contracted Administrative Agent. Vernon shall adopt an Ordinance creating the position of Municipal Housing Liaison. The Municipal Housing Liaison shall be appointed by the governing body and may be a full or part time municipal employee. The Municipal Housing Liaison shall be approved by the Court and shall be duly qualified through a training program sponsored by Affordable Housing Professionals of New Jersey before assuming the duties of Municipal Housing Liaison.
- B. The Municipal Housing Liaison shall be responsible for oversight and administration of the affordable housing program for Vernon, including the following responsibilities which may not be contracted out to the Administrative Agent:
1. Serving as Vernon's primary point of contact for all inquiries from the State, affordable housing providers, Administrative Agents and interested households;
 2. Monitoring the status of all restricted units in Vernon's Fair Share Plan;
 3. Compiling, verifying and submitting annual monitoring reports as may be required by the Court;
 4. Coordinating meetings with affordable housing providers and Administrative Agents, as needed; and
 5. Attending continuing education opportunities on affordability controls, compliance monitoring and affirmative marketing at least annually and more often as needed.
- C. Subject to the approval of the Court, the Township of Vernon shall designate one or more Administrative Agent(s) to administer newly constructed affordable units in accordance with UHAC. An Operating Manual for each affordable housing program shall be provided by the Administrative Agent(s) to be adopted by resolution of the governing body and subject to approval of the Court. The Operating Manual(s) shall be available for public inspection in the office of the Township Clerk, in the office of the Municipal Housing Liaison, and in the office(s) of the Administrative Agent(s). The Municipal Housing Liaison shall supervise the contracting Administrative Agent(s).

§ 133-16 Administrative Agent

- A. The Administrative Agent shall be an independent entity serving under contract to and reporting to the municipality, and in accordance with the requirements of the Act, the Dispute Resolution Program, and N.J.A.C. 5:99-7.
- B. The administrative agent shall administer and enforce the affordability controls set forth in this subsection, which actions are reviewable by the Municipal Housing Liaison pursuant to N.J.S.A. 52:27D-321. The primary responsibility of the administrative agent is to ensure that the restricted units under administration are sold or rented, as applicable, only to very-low-, low-, and moderate-income households. The administrative agent shall also fulfill the requirements and responsibilities identified at N.J.A.C. 5:99-7. Pursuant to N.J.A.C. 5:99-7.2, the administrative agent shall have the authority to discharge and release any or all instruments, as set forth at N.J.A.C. 5:80-26 appendices, filed of record to establish affordability controls.
- C. The municipality is ultimately responsible for the proper administration of the affirmative marketing program, including initial sales, rentals, resales, and re-rentals. The municipality shall also ensure that all affordable unit, applicant, sales records, and other relevant files are returned to the municipality for reporting purposes and to aid with future resales.
- D. The administrative agent is responsible for the affirmative marketing of affordable units, including accepting applications and maintaining a list of applicants for each affordable development. The administrative agent shall document and report the affirmative marketing plan for the municipality and the affirmative marketing activities undertaken for each of the units within their purview to the municipal housing liaison, who shall ensure that developers and administrative agents are marketing units in accordance with the provisions in this section.

§ 133-17 Affirmative Marketing Requirements.

- A. The affirmative marketing plan and all advertisements for the affordable units, must contain the following information:
 - 1. The name and location of the housing project;
 - 2. An address sufficient to find directions to the housing units;
 - 3. A range of prices or rent for the affordable housing units;
 - 4. The sizes, as measured in number of bedrooms and square footage, of the affordable housing units;
 - 5. The types (that is, family, age-restricted, or supportive) and number of affordable units available;
 - 6. The number of units available to very-low-, low-, and moderate-income households within the pertinent eligible income ranges;
 - 7. The accessibility features, if any, of the affordable housing units;
 - 8. The maximum income permitted to qualify for the affordable housing units;

9. The population(s), if any, given preference in the selection process pursuant to N.J.A.C. 5:80-26.17(k)2;
10. Where applications (paper and online) for the affordable housing units may be found;
11. The expected lease-up/closing date(s) for the affordable housing units;
12. A description of the random selection process that will be used to select occupants of affordable housing units and the expected date of the random selection;
13. The business hours when interested households may obtain paper applications for the affordable housing units;
14. Contact information, including an email address and phone number that are regularly monitored by the administrative agent;
15. The name of the sales agent and/or rental manager; and
16. Application fees, if any.

B. In implementing the marketing program, the administrative agent shall:

1. Post a listing of the available affordable housing units to the New Jersey Housing Resource Center at least 60 days before the random selection process or within one day following the date the owner, developer, property manager, or other administrative entity provides information regarding the application process to prospective applicants or solicits any applications from potential applicants through any other means pursuant to N.J.S.A. 52:27D-321.6. It is the responsibility of the Municipal Housing Liaison, in coordination with the administrative agent(s), to ensure compliance with all provisions of N.J.S.A. 52:27D-321.3 through 321.6;
2. Within one business day of listing the affordable housing units on the New Jersey Housing Resource Center, notify the local Continuum of Care of any supportive housing rental units that are reserved for individuals and families that are homeless and of any permanent supportive housing rental units;
3. Publish at least one advertisement in a regional print or digital newspaper;
4. Advertise the units on at least one housing search website, in addition to the Housing Resource Center;
5. Undertake at least two additional regional marketing strategies;
6. Designate an experienced staff person to provide counseling services to low- and moderate-income applicants on subjects such as budgeting, credit issues, mortgage qualification, rental lease requirements, and landlord/tenant law. Alternatively, the administrative agent or municipality may contract with a HUD-certified housing counselor or an otherwise experienced entity approved by the Division to provide such counseling services.

- C. The affirmative marketing process must begin at least four months prior to expected occupancy and may begin before construction commences. All affirmative marketing advertising and outreach activities employed pursuant to (f) above must be employed at the start of the marketing program. For for-sale units, affirmative marketing advertising and outreach activities must continue until all of the marketed units have been sold, except that paid advertising may cease when the number of applications received is at least three times the number of units to be sold. For rental units, affirmative marketing advertising and outreach activities must continue, as long as applications are being accepted, except that paid advertising may cease when the number of applications received is at least three times the number of units to be filled. Applications must be accepted for no less than 45 days following the initial advertisement on the New Jersey Housing Resource Center, except for the resale of for-sale units, in which case, applications must be accepted for no less than 30 days.
- D. No (h) No random selection may be conducted prior to 60 days following the initial advertisement on the New Jersey Housing Resource Center.
- E. Applications for affordable housing or notices thereof, if offered online, must be available in multiple locations, including, if they exist, the county administration building and the county library for each county within the housing region; the municipal administration building(s) and the municipal library in the municipality in which the units are located; and the developer's sales office. The municipality shall post the application links and/or notices of affordable housing either directly on the home page of the municipality's official website or on a landing page directly, clearly, and conspicuously linked to from the home page of the municipality's official website. The developer shall mail applications to prospective applicants upon request and shall make applications available through a secure online website address.
- F. If the municipality intends to require affordable housing developers to incur the cost of affirmative marketing and advertising for affordable units, the municipality must adopt such policy and make the requirement a condition of the project's planning and zoning board approvals.
- G. In carrying out the affirmative marketing process, the administrative agent shall comply with all provisions of the Fair Chance in Housing Act, N.J.S.A. 46:8-52 through 64.

§ 133-18 Enforcement of Affordable Housing Regulations.

- A. The municipal housing liaison is responsible for oversight and coordination of all the activities of the municipal government as they relate to the creation, preservation, and administration of affordable housing programs, affordable units, and reporting. Pursuant to N.J.A.C. 5:99-6.2, such oversight activities include ensuring that administrative agents execute the practices, procedures, and standards set forth in this N.J.A.C. 5:80-26.19, identified in this subsection.
- B. The administrative agent's enforcement responsibility for implementing such practices and procedures may not be delegated or otherwise transferred to any other party, except to a successor administrative agent. Anything in this subchapter to the contrary notwithstanding, the Agency and DCA each may, in its discretion, contract with for-profit and nonprofit organizations to carry out delegated administrative agent functions,

provided, however, that in any such case the Agency or DCA shall maintain primary responsibility for the delegated functions.

- C. As part of a municipality's ongoing compliance with the Act, the municipality, through the municipal housing liaison, shall:
1. Provide to the administrative agent the name, title, email address, and telephone number of the municipal housing liaison who will be responsible for oversight of the administrative agent on all matters related to this subchapter;
 2. If necessary, retain or otherwise designate legal counsel for the purposes of representing any municipal entity acting as administrative agent and of enforcing the controls set forth in this subsection;
 3. Ensure that all restricted units are identified as affordable within the tax assessor's office and any municipal utility authority (MUA). The municipality and MUA shall promptly notify the administrative agent of a change in billing address, payment delinquency of two consecutive billing cycles, transfer of title, or institution of a foreclosure action, foreclosure judgment, or deed in lieu of foreclosure as to all affordable units;
 4. Work with the administrative agent to ensure that affordable housing opportunities are posted to the New Jersey Housing Resource Center pursuant to N.J.S.A. 52:27D-321.3 through 321.6, including, if necessary, levying fines through the process outlined at N.J.A.C. 5:99-5.6(c)4;
 5. Maintain a list of all affordable units within its jurisdiction, including the date of deed restriction expiration, income limits, and the administrative agent for each unit;
 6. Report the information at (c)6 above to the Division each year; and
 7. Publish on the municipality's website the affordable housing operating manual(s) required pursuant to N.J.A.C. 5:99-7.2, the affirmative marketing plan required pursuant to N.J.A.C. 5:80-26.16, and contact information for the administrative agent for each project within the municipality's jurisdiction with an affordable housing component for which affirmative marketing is required.
- D. In addition to those listed at N.J.A.C. 5:99-7.2, administrative agent practices and procedures include, but are not limited to, the following:
1. Securing from all developers and sponsors of restricted units, at the earliest point of contact in the processing of the project or development, written acknowledgement of the requirement that no restricted unit be offered, or in any other way committed, to any person other than a household duly certified to the unit by the administrative agent;
 2. Requiring that all certified applicants for restricted units execute a certificate substantially in the form, as applicable, of either the ownership or rental certificate set forth at N.J.A.C. 5:80-26 Appendix D-3, J, or K;

3. Working with the MHL to ensure that affordable housing opportunities are posted to the New Jersey Housing Resource Center pursuant to N.J.S.A. 52:27D-321.3 through 321.6, including, if necessary, levying fines for noncompliance and requiring new lotteries;
 4. Sending annual mailings to all owners of affordable dwelling units, reminding them of the requirements of N.J.A.C. 5:80-26.19-4(i) through 4(ix).
 5. Securing from municipalities lists of all affordable units for which tax bills are mailed to absentee owners, and notifying all such owners that they must either move back into or sell their unit;
 6. Establishing a program for diverting unlawful rent payments to the municipality's affordable housing trust fund or other appropriate municipal fund approved by the Department.
 7. Establishing a rent-to-equity program, to be implemented in situations where an affordable unit owner has unlawfully rented their unit, and where the tenant has entered into a tenancy without knowledge of its unlawful nature. Under such a rent-to-equity program, the tenant, including the immediate family of the tenant, shall be given an opportunity to purchase the unit from the affordable unit owner, and the affordable unit owner shall be compelled to sell the unit to the tenant, with the total of all rent paid to the owner being credited to the tenant as down payment money paid to the affordable unit owner. Anything in this subchapter to the contrary, notwithstanding, any person offered a unit under such a rent-to-equity program must first be certified as eligible pursuant to N.J.A.C. 5:80-26.17.
- E. It is the responsibility of the municipal housing liaison and the administrative agent(s) to ensure that affordable housing units are administered properly. All affordable units must be occupied within a reasonable amount of time and be re-leased within a reasonable amount of time upon the vacating of the unit by a tenant. If an administrative agent or municipal housing liaison becomes aware of or suspects that a developer, landlord, or property manager has not complied with these regulations, it shall report this activity to the Division. The Division must notify the developer, landlord, or property manager, in writing, of any violation of these regulations and provide a 30-day cure period. If, after the 30-day cure period, the developer, landlord, or property manager remains in violation of any terms of this subchapter, including by keeping a unit vacant, the developer, landlord, or property manager may be fined up to the amount required to construct a comparable affordable unit of the same size and the deed-restricted control period will be extended for the length of the time the unit was out of compliance, in addition to the remedies provided for in this section. For the purposes of this subsection, a reasonable amount of time shall presumptively be 60 days, unless a longer period of time is required due to demonstrable market conditions and/or failure of the municipal housing liaison or the administrative agent to refer a certified tenant.

§ 133-19 Appeals.

Appeals from all decisions of an administrative agent appointed pursuant to this subchapter must be filed, in writing, with the municipal housing liaison for the jurisdiction. A decision by the municipal housing liaison may be appealed to the Division. A written decision of the Division

Director upholding, modifying, or reversing an administrative agent's decision is a final administrative action.

§ 133-20 95/5 Restrictions.

- A. Each existing unit governed by a 95/5 restriction shall be governed according to its deed restriction for the duration of the control period identified in the deed restriction or the municipal resolution extending affordability controls, or, if no control period is identified, until the start of the Fifth Round on July 1, 2035. Following the expiration or release of the 95/5 deed restriction, any extension of affordability controls on the unit must be carried out in accordance with the procedures and instruments outlined at N.J.A.C. 5:80-26.6(h) to receive credit pursuant to the Act.
- B. The owner of a unit governed by a 95/5 restriction shall notify the administrative agent and municipal housing liaison by certified mail and by email of any intent to sell the unit 90 days prior to entering into an agreement for the first authorized non-exempt sale after controls have been in effect on the housing unit for the period specified at N.J.A.C. 5:80-26.6.
- C. Upon receipt of a notice specified at (b) above, the option to buy the unit at the maximum allowable restricted sale price or any mutually agreed upon sale price that does not exceed the maximum allowable restricted sale price will be available for 90 days. The administrative agent shall notify the municipal housing liaison and the Division that the unit is for sale. The municipality shall have the right of first refusal to purchase the unit. If the municipality exercises this option, it may enter into a contract of sale for the unit. If the municipality does not exercise this option within 90 days, the first of the other entities giving notice to the seller of its intent to purchase during the 90-day period may purchase the unit. If the option to purchase the unit at the maximum allowable restricted sale price is not exercised by one of the above entities by a written offer to purchase the housing unit within 90 days of receipt of notice of the intent to sell, the owner may proceed to sell the housing unit pursuant to N.J.A.C. 5:80-26.22. If the owner does not sell the unit within one year of the date of the delivery of the notice of intent to sell, the option to buy the unit will be restored and the owner will be required to submit a new notice of intent to sell 90 days prior to any future proposed date of sale.
- D. Any option to buy a housing unit at the maximum allowable restricted sale price must be exercised by certified mail and, if known, by email and will be deemed to have been exercised three days following the earlier of the postmark of the certified mail or the transmission of the email.

§ 133-21 Seller Option on 95/5 Restrictions.

- A. An eligible seller of a unit governed by a 95/5 restriction that has been controlled for the period established in the governing deed restriction who has provided the requisite notice of an intent to sell may proceed with the sale if no eligible entity exercises its option to purchase within 90 days. The seller may sell the unit to a certified household at an affordable price or to any purchaser at market price.
- B. Subject to this subchapter, the seller may:

1. Sell to a certified household at a price not to exceed the maximum permitted sale price in accordance with N.J.A.C. 5:80-26.7; provided that the unit is regulated by the deed restriction and lien in accordance with N.J.A.C. 5:80-26.6. The administrative agent shall certify the income qualifications of the purchaser and shall ensure that the housing unit is regulated by the deed restriction and lien in accordance with N.J.A.C. 5:80-26.6; or
 2. Exercise the repayment option and sell to any purchaser at market price, provided that 95 percent of the price differential, or another amount determined by an ordinance of the municipal governing body, not to exceed 95 percent of the price differential, is paid to the Municipal Affordable Housing Trust Fund, through the administrative agent, as an instrumentality of the municipality, at closing. Any alternative amount or formula for calculating the alternative amount determined by such ordinance must be uniformly available to all sellers exercising the repayment option within the municipality.
- C. The administrative agent shall examine any contract of sale containing a repayment option to determine if the proposed sale price bears a reasonable relationship to the housing unit's fair market value. In making this determination, the administrative agent may rely on comparable sales data or an appraisal. The administrative agent shall not approve any contract of sale where there is a determination that the sale price does not bear a reasonable relationship to fair market value. The administrative agent shall make such a determination within 20 days of receipt of the contract of sale and shall calculate the repayment option payment.
- D. The administrative agent shall adopt an appeal procedure by which a seller may submit written documentation requesting the administrative agent to recompute the repayment obligation if the seller believes an error has been made, or to reconsider a determination that a sale price does not bear a reasonable relationship to fair market value. A repayment obligation determination made as a result of an owner's appeal is a final determination of the administrative agent appealable pursuant to N.J.A.C. 5:80-26.20.
- E. The repayment will occur at the date of closing and transfer of title for the first non-exempt transaction after the expiration of controls on affordability.
- F. The administrative agent shall deposit all repayment proceeds into the Municipal Housing Trust Fund, which may be used as specified at N.J.S.A. 52:27D-329.2. Money deposited in housing trust funds may not be expended until the municipality submits and the Division or the county-level housing judge approves a spending plan. See N.J.A.C. 5:99-2 and N.J.S.A. 52:27D-329.2.

CERTIFICATION

This is to certify that the above Ordinance was introduced and passed on first reading at the Meeting of the Township Council held on February 9, 2026, and the same came up for final passage and was adopted at the Meeting of the Township Council held on March 9, 2025 at which time all persons interested were given an opportunity to be heard. The above ordinance will be in full force and effect in the Township of Vernon according to law.

Marcy Gianattasio, Clerk
Township of Vernon

Anthony Rossi, Mayor

Township of Vernon

INTRODUCED: February 9, 2026

NAME	M	S	YES	NO	ABSTAIN	ABSENT
Contino C.	X		X			
Ooms S.		X	X			
Rizzuto R.			X			
Sparta, B.			X			
Higgins W.			X			

ADOPTED:

NAME	M	S	YES	NO	ABSTAIN	ABSENT
Contino C.						
Ooms S.						
Rizzuto P.						
Sparta, B.						
Higgins W.						

TOWNSHIP OF VERNON

ORDINANCE #26-06

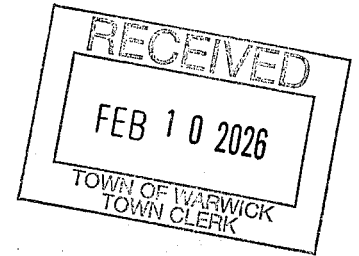

**ORDINANCE TO REPEAL AND REPLACE THE EXISTING ARTICLE XIV,
"AFFORDABLE HOUSING" OF THE MUNICIPAL CODE OF THE TOWNSHIP OF
VERNON**

This Ordinance repeals and replaces the existing Article XIV, "Affordable Housing" of Vernon Township's municipal code.

Article XIV Development Fees.

§ 330-212 Development Fees.

A. Purpose; legislative authority.

- (1) This section establishes standards for the collection, maintenance, and expenditure of development fees in accordance with P.L.2024, c.2, Sections 8 and 32-38. Fees collected pursuant to this section shall be used for the sole purpose of providing low- and moderate-income housing. This section shall be interpreted within the framework of the DCA's rules on development fees, codified at N.J.A.C. 5:97-8.
- (2) The collection of development fees from builders of residential and non-residential properties has been authorized by the court through the powers established pursuant to the "Fair Housing Act," P.L.1985, c.222 (C.52:27D-301 et al.). Due to the Legislature's determination that the role of the Council on Affordable Housing has not developed in practice as intended, the Legislature further determines that authority relating to rulemaking on the collection of residential and non-residential development fees is appropriately delegated to the Department of Community Affairs (the Department), given the department's existing roles related to local government finance and the funding and financing of affordable housing throughout the State.

B. Definitions. The following terms, as used in this section, shall have the following meanings:

AFFORDABLE HOUSING DEVELOPMENT — A development included in the Housing Element and Fair Share Plan, and includes, but is not limited to, an inclusionary development, a municipal construction project or a one-hundred-percent affordable development.

COAH or COUNCIL — means the Council on Affordable Housing established in, but not of, DCA by the Act and that was abolished effective March 20, 2024 by section 3 of P.L. 2024, c.2 (N.J.S.A. 52:27D-304.1).

CONSTRUCTION — Means new construction and additions, but does not include alterations, reconstruction, renovations, and repairs as those terms are defined under the State Uniform Construction Code promulgated pursuant to the "State Uniform Construction Code Act," P.L. 1975, c.217 (N.J.A.C. 52:27D-119 et seq.)

COMMISSIONER — means the Commissioner of Community Affairs.

DEPARTMENT — means the Department of Community Affairs.

PROGRAM — The Affordable Housing Dispute Resolution Program, established pursuant to section 5 of P.L.2024, c.2 (N.J.A.C. 52:27D-313.2). The Program has the purpose of efficiently resolving disputes involving the Fair Housing Act.

DEVELOPER — The legal or beneficial owner or owners of a lot or of any land proposed to be included in a proposed development, including the holder of an option or contract to purchase, or other person having an enforceable proprietary interest in such land.

DEVELOPMENT FEE — Money paid by a developer for the improvement of property as permitted in N.J.A.C. 5:97-8.3.

EQUALIZED ASSESSED VALUE — The assessed value of a property divided by the current average ratio of assessed to true value for the municipality in which the property is situated, as determined in accordance with sections 1, 5, and 6 of P.L.1973, c.123 (N.J.S.A. 54:1-35a through N.J.S.A. 54:1-35c).

MIXED-USE DEVELOPMENT — Means any development which includes both a non-residential development component and a residential development component, and shall include developments for which (1) there is a common developer for both the residential development component and the non-residential development component, provided that for purposes of this definition, multiple persons and entities may be considered a common developer if there is a contractual relationship among them obligating each entity to develop at least a portion of the residential or non-residential development, or both, or otherwise to contribute resources to the development; and (2) the residential and non-residential developments are located on the same lot or adjoining lots, including but not limited to lots separated by a street, a river, or another geographical feature.

AGENCY — The New Jersey Housing and Mortgage Finance Agency.

NON-RESIDENTIAL DEVELOPMENT — Means: (1) any building or structure, or portion thereof, including but not limited to any appurtenant improvements, which is designated to a use group other than a residential use group according to the State Uniform Construction Code promulgated to effectuate the "State Uniform Construction Code Act," P.L.1975, c.217 (C.52:27D-119 et seq.), including any subsequent amendments or revisions thereto; (2) hotels, motels, vacation timeshares, and child-care facilities; and (3) the entirety of all continuing care facilities within a continuing care retirement community which is subject to the "Continuing Care Retirement Community Regulation and Financial Disclosure Act," P.L.1986, c.103 (C.52:27D-330 et seq.).

NON-RESIDENTIAL DEVELOPMENT FEE — means the fee authorized to be imposed pursuant to sections 32 through 38 of P.L.2008, c.46 (C.40:55D-8.1 through C.40:55D-8.7).

UHAC — The Uniform Housing Affordability Controls. UHAC governs how a municipality meets its housing need once defined, and how affordable housing units in that town's plan are administered.

C. Residential development fees.

(1) Imposed fees.

- i. Within Vernon Township's affordable housing district(s), residential developers, except for developers of the types of development specifically exempted below, shall pay a fee of 1.5% of the equalized assessed value for residential development, provided no increased density is permitted.
- ii. When an increase in residential density pursuant to N.J.S.A. 40:55D-70d(5) (known as a "d" variance) has been permitted, developers may be required to pay a development fee of 6% of the equalized assessed value for each additional unit that may be realized. However, if the zoning on a site has changed during the two-year period preceding the filing of such a variance application, the base density for the purposes of calculating the bonus development fee shall be the highest density permitted by right during the two-year period preceding the filing of the variance application. Example: If an approval allows four units to be constructed on a site that was zoned for two units, the fees could equal 1.5% of the equalized assessed value on the first two units; and the specified higher percentage up to 6% of the equalized assessed value for the two additional units, provided zoning on the site has not changed during the two-year period preceding the filing of such a variance application.
- iii. Development fees shall be imposed and collected when an existing structure undergoes a change to a more intense use, is demolished and replaced, or is expanded, if the expansion is not otherwise exempt from the development fee requirement. The development fee shall be calculated on the increase in the equalized assessed value of the improved structure.
- iv. Single-family additions shall be exempt from paying a development fee.
- v. One- and two-family owner-occupied residential structures demolished and replaced as a result of a fire, flood, or natural disaster shall be exempt from paying a development fee.

D. Nonresidential development fees.

(1) Imposed fees.

- i. Within all zoning districts, nonresidential developers, except for developers of the types of development specifically exempted, shall pay a fee equal to 2.5% of the equalized assessed value of the land and improvements, for all new nonresidential construction on an unimproved lot or lots.
- ii. Nonresidential developers, except for developers of the types of development specifically exempted, shall also pay a fee equal to 2.5% of the increase in equalized assessed value resulting from any additions to existing structures to be used for nonresidential purposes.
- iii. Development fees shall be imposed and collected when an existing structure is demolished and replaced. The development fee of 2.5% shall be calculated on the difference between the equalized assessed value of

the preexisting land and improvement and the equalized assessed value of the newly improved structure, i.e., land and improvement, at the time final certificate of occupancy is issued. If the calculation required under this section results in a negative number, the nonresidential development fee shall be zero.

(2) Eligible exactions ineligible exactions, and exemptions for nonresidential development.

- i. The nonresidential portion of a mixed-use inclusionary or market rate development shall be subject to the development fee of 2.5%, unless otherwise exempted below.
- ii. The fee of 2.5% shall not apply to an increase in equalized assessed value resulting from alterations, change in use within existing footprint, reconstruction, renovations and repairs.
- iii. Nonresidential developments shall be exempt from the payment of nonresidential development fees in accordance with the exemptions required pursuant to P.L.2008, c.46, as specified in the Form N-RDF "State of New Jersey Non-Residential Development Certification/Exemption." Any exemption claimed by a developer shall be substantiated by that developer.
- iv. A developer of a nonresidential development exempted from the nonresidential development fee pursuant to P.L.2008, c.46 shall be subject to it at such time the basis for the exemption no longer applies, and shall make the payment of the nonresidential development fee, in that event, within three years after that event or after the issuance of the final certificate of occupancy of the nonresidential development, whichever is later.
- v. If a property which was exempted from the collection of a nonresidential development fee thereafter ceases to be exempt from property taxation, the owner of the property shall remit the fees required pursuant to this section within 45 days of the termination of the property tax exemption. Unpaid nonresidential development fees under these circumstances may be enforceable by Vernon Township as a lien against the real property of the owner.

(3) Collection procedures.

- i. Upon the granting of a preliminary, final or other applicable approval for a development, the applicable approving authority shall direct its staff to notify the construction official responsible for the issuance of a building permit.
- ii. For nonresidential developments only, the developer shall also be provided with a copy of Form N-RDF "State of New Jersey Non-Residential Development Certification/ Exemption" to be completed as per the instructions provided. The developer of a nonresidential development shall complete Form N-RDF as per the instructions provided. The construction official shall verify the information submitted by the nonresidential

- developer as per the instructions provided in the Form N-RDF. The Tax Assessor shall verify exemptions and prepare estimated and final assessments as per the instructions provided in Form N-RDF.
- iii. The construction official responsible for the issuance of a building permit shall notify the local Tax Assessor of the issuance of the first building permit for a development which is subject to a development fee.
 - iv. Within 90 days of receipt of that notice, the municipal Tax Assessor, based on the plans filed, shall provide an estimate of the equalized assessed value of the development.
 - v. The construction official responsible for the issuance of a final certificate of occupancy notifies the local assessor of any and all requests for the scheduling of a final inspection on property which is subject to a development fee.
 - vi. Within 10 business days of a request for the scheduling of a final inspection, the municipal assessor shall confirm or modify the previously estimated equalized assessed value of the improvements of the development; calculate the development fee; and thereafter notify the developer of the amount of the fee.
 - vii. Should Vernon Township fail to determine or notify the developer of the amount of the development fee within 10 business days of the request for final inspection, the developer may estimate the amount due and pay that estimated amount consistent with the dispute process set forth in subsection b. of section 37 of P.L.2008, c.46 (N.J.S.A. 40:55D-8.6).
 - viii. Fifty percent of the development fee shall be collected at the time of issuance of the building permit. The remaining portion shall be collected at the issuance of the certificate of occupancy. The developer shall be responsible for paying the difference between the fee calculated at building permit and that determined at issuance of certificate of occupancy.
 - ix. Appeal of development fees.

[1] A developer may challenge residential development fees imposed by filing a challenge with the County Board of Taxation. Pending a review and determination by the Board, collected fees shall be placed in an interest-bearing escrow account by Vernon Township. Appeals from a determination of the Board may be made to the tax court in accordance with the provisions of the State Tax Uniform Procedure Law, N.J.S.A. 54:48-1 et seq., within 90 days after the date of such determination. Interest earned on amounts escrowed shall be credited to the prevailing party.

[2] A developer may challenge nonresidential development fees imposed by filing a challenge with the Director of the Division of Taxation. Pending a review and determination by the Director, which shall be made within 45 days of receipt of the challenge, collected

fees shall be placed in an interest-bearing escrow account by Vernon Township. Appeals from a determination of the Director may be made to the tax court in accordance with the provisions of the State Tax Uniform Procedure Law, N.J.S.A. 54:48-1 et seq., within 90 days after the date of such determination. Interest earned on amounts escrowed shall be credited to the prevailing party.

E. Affordable Housing Trust Fund.

- (1) There hereby created a separate, interest-bearing housing trust fund to be maintained by the chief financial officer for the purpose of depositing development fees collected from residential and nonresidential developers and proceeds from the sale of units with extinguished controls.
- (2) The following additional funds shall be deposited in the Affordable Housing Trust Fund and shall at all times be identifiable by source and amount:
 - i. Payments in lieu of on-site construction of affordable units;
 - ii. Developer-contributed funds to make 10% of the adaptable entrances in a townhouse or other multistory attached development accessible;
 - iii. Rental income from municipally operated units; Repayments from affordable housing program loans; Recapture funds;
 - iv. Proceeds from the sale of affordable units; and
 - v. Any other funds collected in connection with Vernon Township's affordable housing program.
- (3) Within seven days from the opening of the trust fund account, Vernon Township shall provide DCA with written authorization, in the form of a three-party escrow agreement between the municipality, the bank and DCA to permit DCA to direct the disbursement of the funds as provided for in N.J.A.C. 5:97-8.13(b).
- (4) All interest accrued in the Housing Trust Fund shall only be used on eligible affordable housing activities approved by DCA .
- (5) Use of funds.
 - i. The expenditure of all funds shall conform to a spending plan approved by DCA. Funds deposited in the Housing Trust Fund may be used for any activity approved by DCA to address the Vernon Township's fair share obligation and may be set up as a grant or revolving loan program. Such activities include, but are not limited to, preservation or purchase of housing for the purpose of maintaining or implementing affordability controls, rehabilitation, new construction of affordable housing units and related costs, accessory apartment, market to affordable, or regional housing partnership programs, conversion of existing nonresidential buildings to create new affordable units, green building strategies designed to be cost saving and in accordance with accepted national or state standards,

purchase of land for affordable housing, improvement of land to be used for affordable housing, extensions or improvements of roads and infrastructure to affordable housing sites, financial assistance designed to increase affordability, administration necessary for implementation of the Housing Element and Fair Share Plan, or any other activity as permitted pursuant to N.J.A.C. 5:97-8.7 through 8.9 and specified in the approved spending plan.

- ii. Funds shall not be expended to reimburse Vernon Township for past housing activities.
- iii. At least 30% of all development fees collected or such amount as approved through the DCA waiver process and interest earned shall be used to provide affordability assistance to low- and moderate-income households in affordable units included in the municipal Fair Share Plan. One-third of the affordability assistance portion of development fees collected shall be used to provide affordability assistance to those households earning 30% or less of median income by region.

[1] Affordability assistance programs may include down-payment assistance, security-deposit assistance, low-interest loans, rental assistance, assistance with homeowners' association or condominium fees and special assessments, and assistance with emergency repairs.

[2] Affordability assistance to households earning 30% or less of median income may include buying down the cost of low- or moderate-income units in the municipal Fair Share Plan to make them affordable to households earning 30% or less of median income.

- (6) Payments in lieu of constructing affordable units on site and funds from the sale of units with extinguished controls shall be exempt from the affordability assistance requirement
- (7) Vernon Township may contract with a private or public entity to administer any part of its Housing Element and Fair Share Plan, including the requirement for affordability assistance, in accordance with N.J.A.C. 5:96-18.
- (8) No more than 20% of all revenues collected from development fees may be expended on administration, including, but not limited to, salaries and benefits for municipal employees or consultant fees necessary to develop or implement a new construction program, a Housing Element and Fair Share Plan, and/or an affirmative marketing program. In the case of a rehabilitation program, no more than 20% of the revenues collected from development fees shall be expended for such administrative expenses. Administrative funds may be used for income qualification of households, monitoring the turnover of sale and rental units, and compliance with DCA's monitoring requirements. Legal or other fees related to litigation opposing affordable housing sites or objecting to the DCA's regulations and/or action are not eligible uses of the affordable housing trust fund.

F. Monitoring.

- (1) Vernon Township shall complete and return to DCA all monitoring forms included in monitoring requirements related to the collection of development fees from residential and nonresidential developers, payments in lieu of constructing affordable units on site, funds from the sale of units with extinguished controls, barrier free escrow funds, rental income, repayments from affordable housing program loans, and any other funds collected in connection with Vernon Township's housing program, as well as to the expenditure of revenues and implementation of the plan certified by the Program. Monitoring will be completed through the Affordable Housing Monitoring System (AHMS).

G. Ongoing collection of fees.

- (1) The ability for Vernon Township to impose, collect and expend development fees shall expire with its substantive certification unless Vernon Township has filed an adopted Housing Element and Fair Share Plan with DCA, has petitioned for substantive certification, and has received DCA's approval of its Development Fee Ordinance. If Vernon Township fails to renew its ability to impose and collect development fees prior to the expiration of substantive certification, it may be subject to forfeiture of any or all funds remaining within its municipal trust fund. Any funds so forfeited shall be deposited into the "New Jersey Affordable Housing Trust Fund" established pursuant to section 20 of P.L.1985, c.222 (N.J.S.A. 52:27D-320). Vernon Township shall not impose a residential development fee on a development that receives preliminary or final site plan approval after the expiration of its substantive certification or judgment of compliance; nor shall Vernon Township retroactively impose a development fee on such a development. Vernon Township shall not expend development fees after the expiration of its substantive certification.

CERTIFICATION

This is to certify that the above Ordinance was introduced and passed on first reading at the Meeting of the Township Council held on February 9, 2026, and the same came up for final passage and was adopted at the meeting of the Township Council held on March 9, 2025 at which time all persons interested were given an opportunity to be heard. The above ordinance will be in full force and effect in the Township of Vernon according to law.

Marcy Gianattasio, Clerk
Township of Vernon

Anthony Rossi, Mayor

Township of Vernon

INTRODUCED: February 9, 2026

NAME	M	S	YES	NO	ABSTAIN	ABSENT
Contino C.		X	X			
Ooms S.	X		X			
Rizzuto R.			X			
Sparta, B.			X			
Higgins W.			X			

ADOPTED:

NAME	M	S	YES	NO	ABSTAIN	ABSENT
Contino C.						
Ooms S.						
Rizzuto P.						
Sparta, B.						
Higgins W.						

Warwick Town Clerk

From: ippi3635@aol.com
Sent: Monday, February 16, 2026 12:43 PM
To: bizdata@warwick.net; mayor@villageofwarwick.org; clerk@villageofwarwick.org; Town of Warwick Supervisor; Town Supervisors Confidential Secretary; Warwick Town Clerk; esiljkovic@orangecountygov.com; mdeshler@thetownofchester.org; kate@wallradio.com; cheney@villageofwarwick.org; llaico@rcls.org; bangell@rcls.org; becca.tucker@strausnews.com; sherry zambrzycki; Laura Shanahan; Chester Library
Subject: Warwick Repair Cafe - Saturday March 21, 2026
Attachments: May 16, 2026 Repair Cafe Flyer.docx

The next Warwick Repair Cafe will be Saturday March 21, 2026, 10am to 2pm at the Warwick Senior Center, 132 Kings Hiway, Warwick.
Thank you for your continued support.

Flyer attached. Please post and pass the word.....

Thank you

Joan Maxwell
Organizer Warwick Repair Cafe

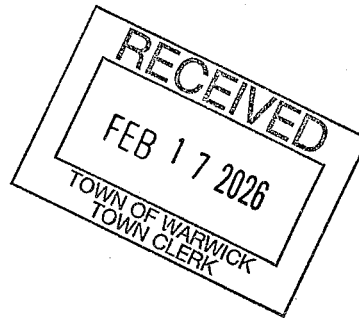



Saturday, Mar, 21, 2026 10 AM-2:00 PM
Senior Center, Town Hall Complex, 132 Kings Hwy, Warwick

Bring Your BELOVED BUT BROKEN Items
***FIX Them for FREE With Our Repair Coaches**

*Lamp parts - Available at our cost

Lamp & Bike Repairs

Mechanical & Electrical

Quick Repairs & Consultations

Laptops, Tablets, Cell Phones

Bikes, Jewelry, Wooden Things, Clocks

Clothing, Home Textiles, Soft Toys

Knife & Tool Sharpening Limit

TWO Items Per Person, PLS.!

Sorry, no gas or propane-powered items

Repaircafehv.org organizerwarwickrepaircafe@aol.com